

EXPERIMENT MANUAL

ENGINEERING MAKERSPACE

ALIEN ROBOTS

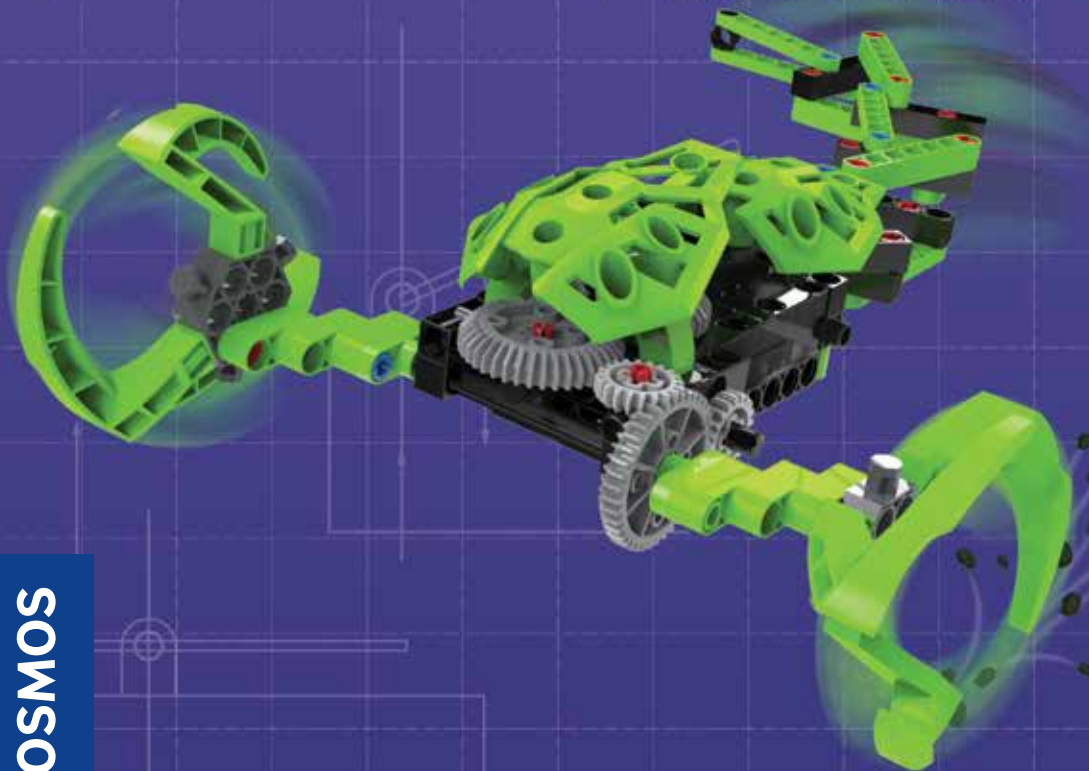

 THAMES & KOSMOS

Franckh-Kosmos Verlags-GmbH & Co. KG, Pfizerstr. 5-7, 70184 Stuttgart, Germany | +49 (0) 711 2191-0 | www.kosmos.de
Thames & Kosmos, 301 Friendship St., Providence, RI, 02903, USA | 1-800-587-2872 | www.thamesandkosmos.com
Thames & Kosmos UK LP, 20 Stone Street, Cranbrook, Kent, TN17 3HE, UK | 01580 713000 | www.thamesandkosmos.co.uk



SAFETY INFORMATION

Warning! Not suitable for children under 3 years. Choking hazard — small parts may be swallowed or inhaled.

Keep the packaging and the instructions as they contain important information.

Store the experiment materials and assembled models out of the reach of small children.

The models are intended for indoor use. Do not use your models in a sandbox.

Safety Advice for Batteries

- ››› Two AA batteries (1.5-volt, type LR6) are required for operation.
- ››› The supply terminals are not to be short-circuited. A short circuit can cause the wires to overheat and the batteries to explode.
- ››› Different types of batteries (e.g., rechargeable and standard) or new and used batteries are not to be mixed.
- ››› Do not mix old and new batteries.
- ››› Do not mix alkaline, standard (carbon-zinc), or rechargeable (nickel-cadmium) batteries.
- ››› Batteries are to be inserted with the correct polarity. Press them gently into the battery compartment. See page 2.
- ››› Always close the battery compartment with the lid.
- ››› Non-rechargeable batteries are not to be recharged. They could explode!
- ››› Rechargeable batteries are only to be charged under adult supervision.
- ››› Rechargeable batteries are to be removed from the toy before being charged.
- ››› Exhausted batteries are to be removed from the toy.
- ››› Dispose of used batteries in accordance with environmental provisions, not in the household trash.
- ››› Be sure not to bring batteries into contact with coins, keys, or other metal objects.
- ››› Avoid deforming the batteries.
- ››› Please remove the batteries if the toy is likely to be unused for a long time.

Dear Parents and Adults,

Before starting the experiments, read through the instruction manual together with your child and discuss the safety information. Check to make sure the models have been assembled correctly, and assist your child with the experiments.

We hope you and your child have a lot of fun with the experiments!

Notes on Disposal of Electrical and Electronic Components

The electronic components of this product are recyclable. For the sake of the environment, do not throw them into the household trash at the end of their lifespan.

They must be delivered to a collection location for electronic waste, as indicated by the following symbol:



Please contact your local authorities for the appropriate disposal location.

>>> KIT CONTENTS

You will also need: 2 x AA batteries (1.5 Volt, type LR6)

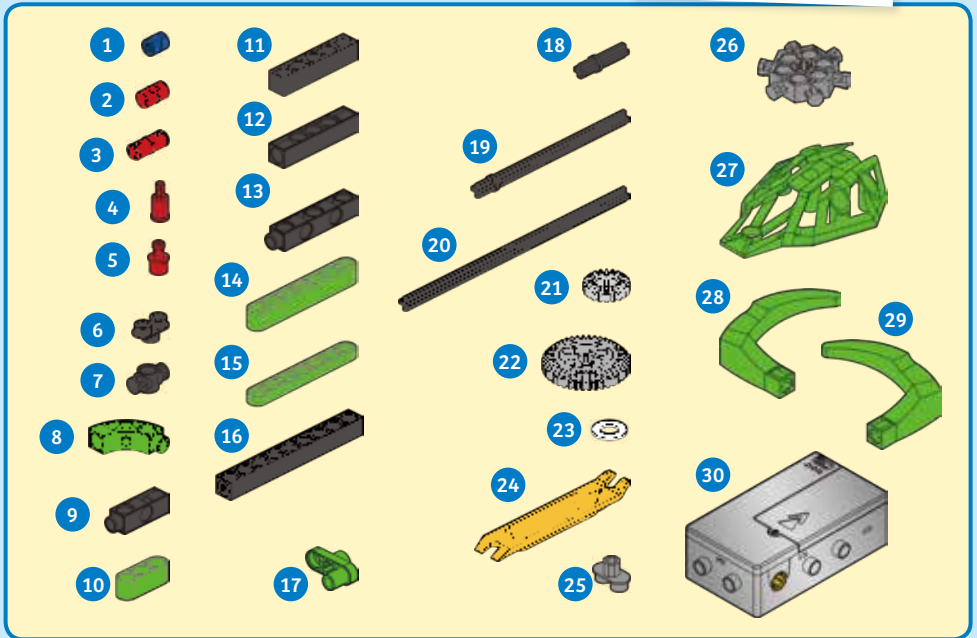

Checklist: Find – Inspect – Check off

✓	No.	Description	Qty.	Item No.
<input type="radio"/>	1	Short anchor pin	30	717767
<input type="radio"/>	2	Anchor pin	10	702527
<input type="radio"/>	3	Joint pin	16	702524
<input type="radio"/>	4	Shaft pin	4	702526
<input type="radio"/>	5	Shaft plug	4	702525
<input type="radio"/>	6	Two-to-one converter, black	2	716889
<input type="radio"/>	7	1-hole connector	3	719233
<input type="radio"/>	8	Curved rod	2	717838
<input type="radio"/>	9	3-hole dual rod	1	716859
<input type="radio"/>	10	3-hole wide rounded rod	6	717837
<input type="radio"/>	11	5-hole rod B	8	716876
<input type="radio"/>	12	5-hole cross rod	2	716677
<input type="radio"/>	13	5-hole dual rod B	2	720583
<input type="radio"/>	14	7-hole wide rounded rod	6	717901
<input type="radio"/>	15	7-hole flat rounded rod	6	717900

✓	No.	Description	Qty.	Item No.
<input type="radio"/>	16	9-hole rod	4	717806
<input type="radio"/>	17	3-hole crank	2	718284
<input type="radio"/>	18	Axle, 30 mm	2	716860
<input type="radio"/>	19	Axle, 100 mm	1	716901
<input type="radio"/>	20	Axle, 150 mm	1	703518
<input type="radio"/>	21	Small gear	2	716885
<input type="radio"/>	22	Medium gear	4	716890
<input type="radio"/>	23	Washer	2	703242
<input type="radio"/>	24	Anchor pin lever	1	702590
<input type="radio"/>	25	Two-to-one converter, gray	6	720774
<input type="radio"/>	26	6-pin hub connector	2	720775
<input type="radio"/>	27	Main body piece	2	720779
<input type="radio"/>	28	Claw piece A	3	720777
<input type="radio"/>	29	Claw piece B	3	720778
<input type="radio"/>	30	Motor and battery box	1	719861



TIPS FOR ASSEMBLY

THE ANCHOR PIN LEVER

Side A of the lever can be used to easily remove anchor pins.

Side B can be used to loosen firmly inserted parts, such as axle plugs.



BATTERIES How to insert and remove the batteries

Open the battery compartment by sliding the lid open. Insert two batteries. Make sure you fit the positive and negative ends into the compartment in the direction indicated (with the correct polarity). Then close the compartment. When it is time to replace the batteries, remove the old batteries and insert the new ones with the correct polarity.

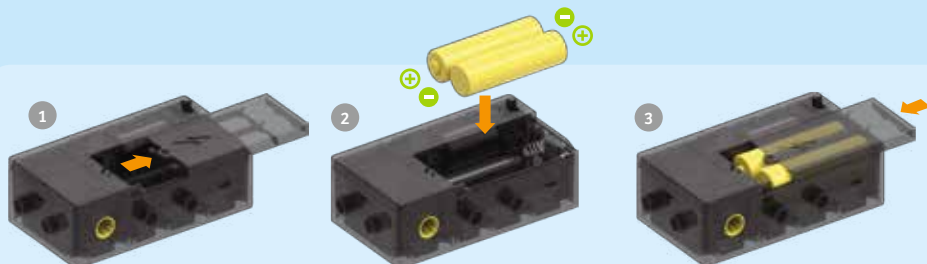

>>> TABLE OF CONTENTS

Safety Information ... Inside front cover	
Kit Contents	1
Tips for Assembly	2
Table of Contents	3
Overview	4
Check It Out	6
1. Alien Snake-Bot	8
2. Insectoid-Bot	12
3. Rolling Dragon-Bot	15
4. Grabber Claw	19
5. Alien Raptor	22
6. Roving Dino-Bot	25
7. Playground Swing	29
8. Bipedal Robot	31
9. Pumpjack	34
10. Alien Frog-Bot	36
Check It Out	40

On pages 4–5 you can see all the models at a glance.



Learn more about levers, including the anchor pin lever, on pages 6–7. Learn about linkages on page 40.





>>> OVERVIEW

Alien Snake-Bot

8



12

Insectoid-Bot



Bipedal Robot

31



Playground Swing

29



Rolling Dragon-Bot

15



Build these functional models one at a time!

>>> OVERVIEW

19



Grabber
Claw

25



Roving
Dino-Bot



Alien
Raptor

22



Alien
Frog-Bot

36

Pumpjack

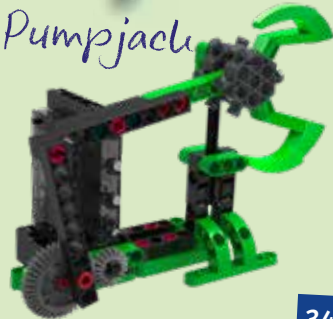

34

>>> CHECK IT OUT



THE ANCHOR PIN LEVER

The anchor pin lever in your experiment kit also uses a lever like this so that you can take the components apart more easily. The pivot point is between the two lever arms, so we call it a “double-sided lever.”

>>> A wheelbarrow uses a different kind of leverage to reduce the amount of force needed to lift a load.



THE LEVER

A **lever** is a simple machine used to raise or move an object; it consists of a rigid beam that can pivot on a fixed point, called the **fulcrum**. The side on which the load to be moved is located is called the **load arm**. The other side, on which the moving force is applied, is called the **force arm**.

>>> **Everyday examples include seesaws, crowbars, and wrenches.**

These tools and toys take advantage of the fact that you can generate a great force by exercising a small force if you move farther away to do so.



In this case, the wheel of the wheelbarrow is the pivot (fulcrum) of the lever. The two lever arms constitute the distance to the center of gravity of the load and the distance to the hold point of the wheelbarrow. Because both lever arms are on the same side, this type of lever is called a “one-sided lever.” But the principle is the same as with the anchor pin lever!

>>> CHECK IT OUT

THE FORCES ON A LEVER

The fulcrum is the spot on the bottom of the anchor pin lever that doesn't move when the tool is used to pry up a pin. The two arms pivot around this point.

Load Arm and Force Arm

When you press on the handle with enough effort force for the anchor pin to come out of its hole, the part separator tool is in a state of balance or equilibrium in its work. The arm of the lever on the effort side is longer in proportion to the degree that the effort force is smaller. The opposite happens on the load side. The load arm is shorter in proportion to the degree that the load force is greater. If the effort arm is twice as long as the load arm, then there is a balance when the effort force is half as great as the load force. Effort force (kg) times the distance on the effort arm from the exertion point of the effort force to the fulcrum (m) is equal to load force (kg) times the distance from the load force to the fulcrum (m). Written a little differently, this is how the equation goes:

$$\begin{aligned} \text{effort force} \times \text{effort arm length} \\ = \\ \text{load force} \times \text{load arm length} \end{aligned}$$

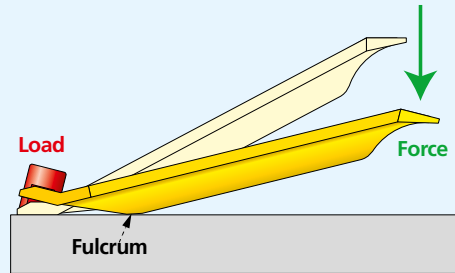
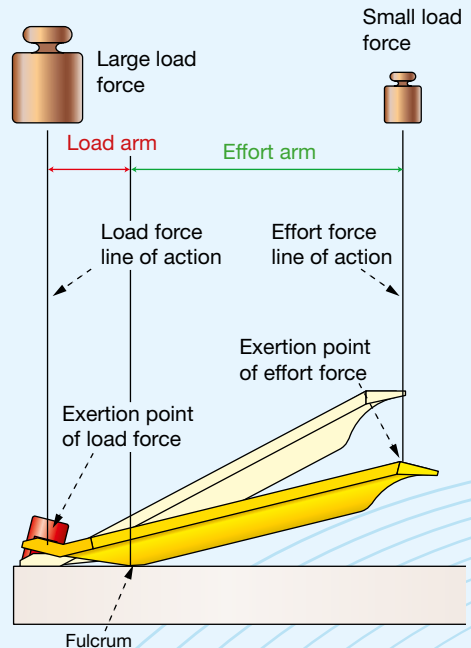
**Diagram: Lever**

>>> Look for levers
in the models you
build!



ALIEN SNAKE-BOT

1

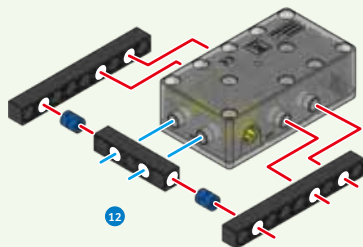

2

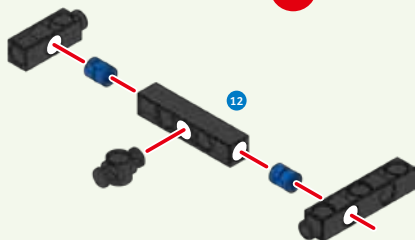

3

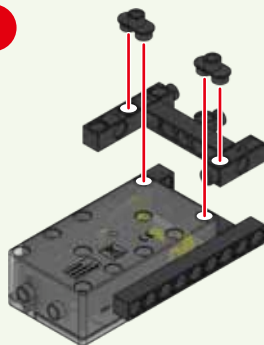

4

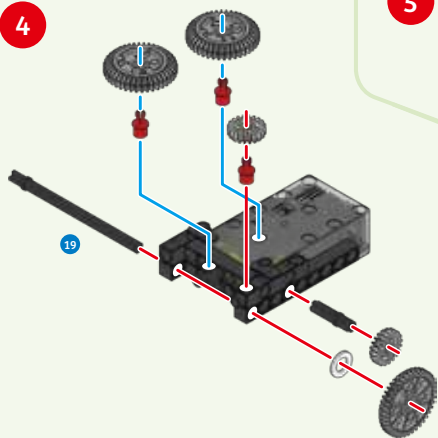

5

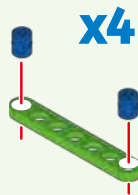

6

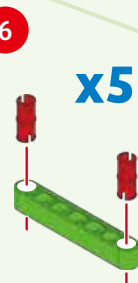

7

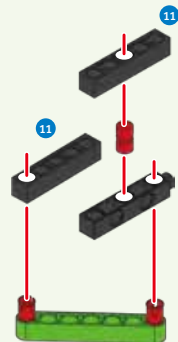

ALIEN SNAKE-BOT

8

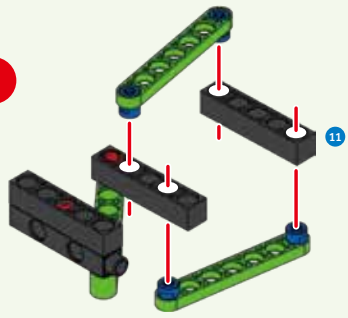

9

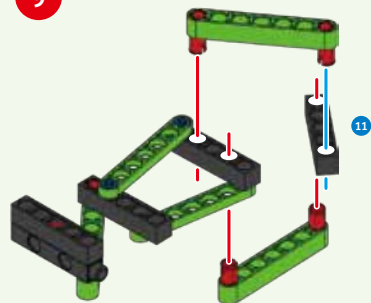

10

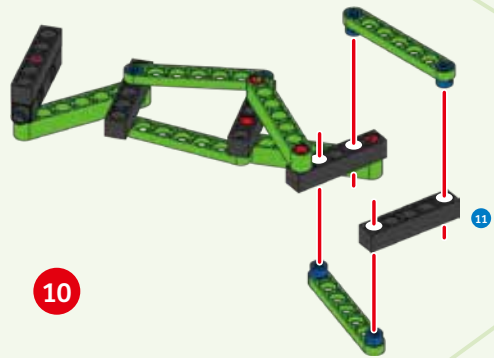

11

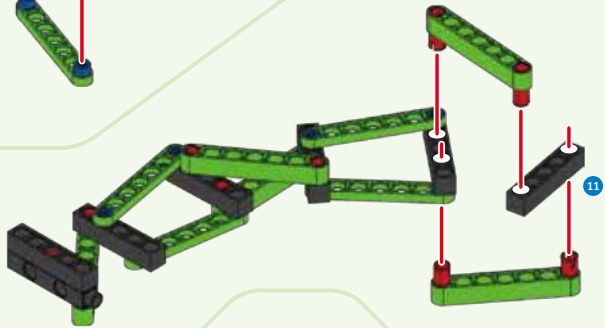

12

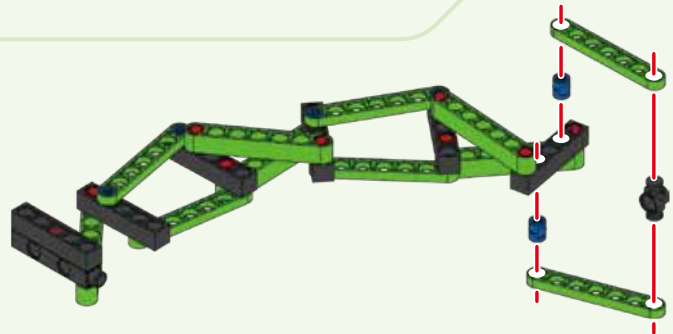



ALIEN SNAKE-BOT

13

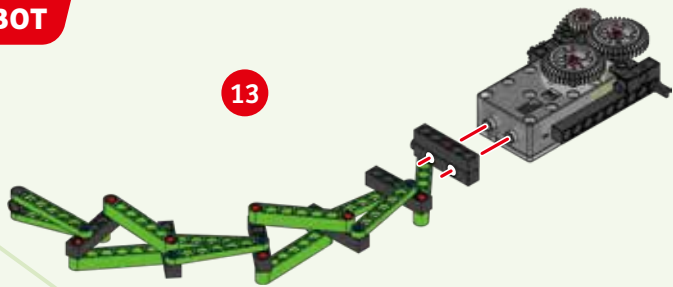

11

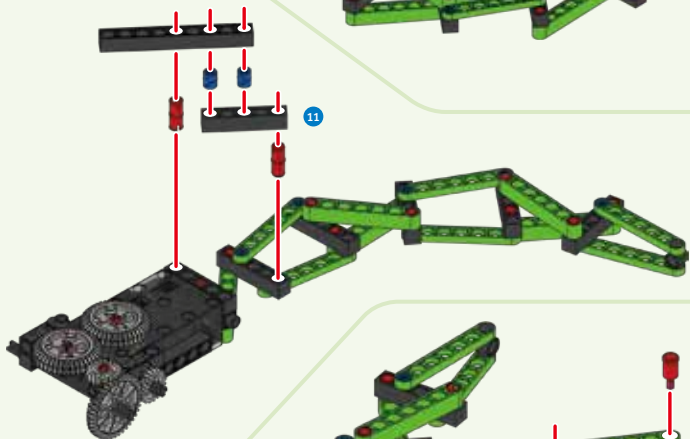

14

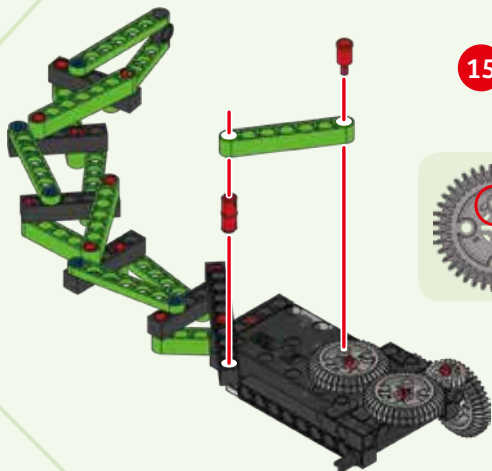

15

16

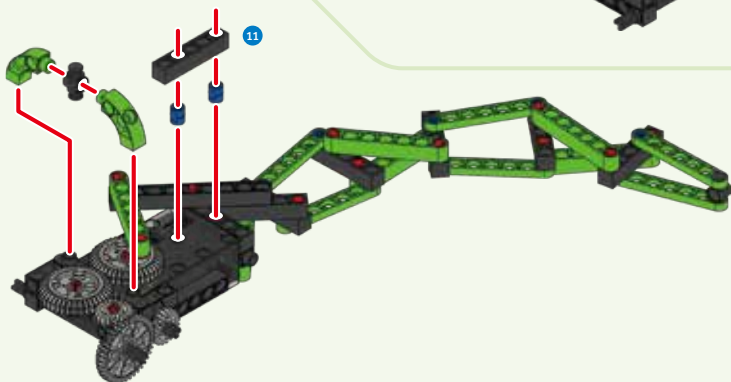

ALIEN SNAKE-BOT

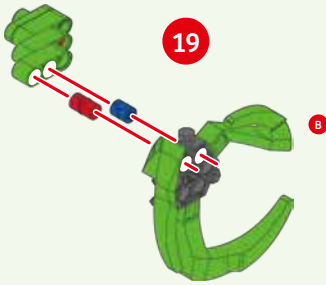
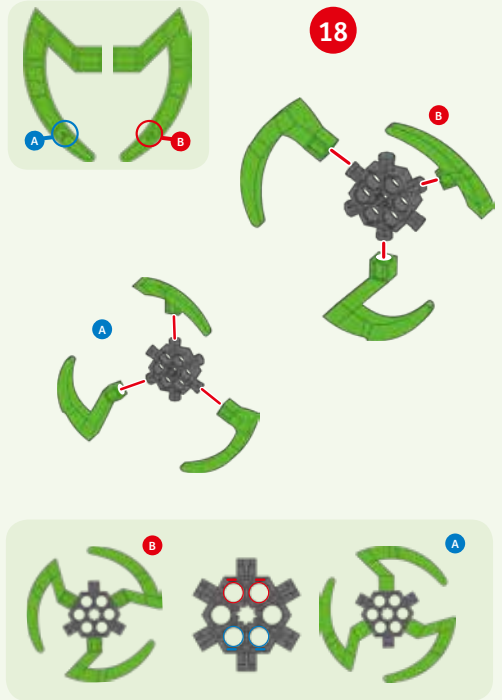
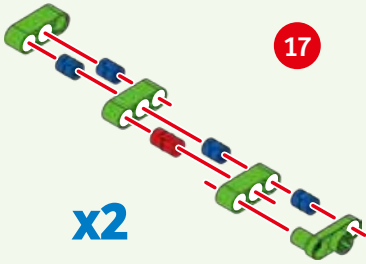

21

Done!





INSECTOID-BOT

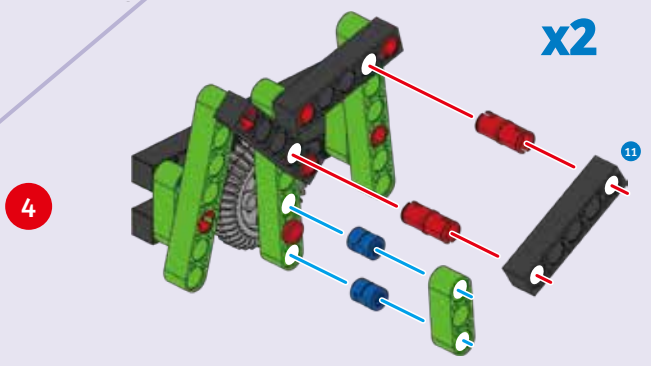
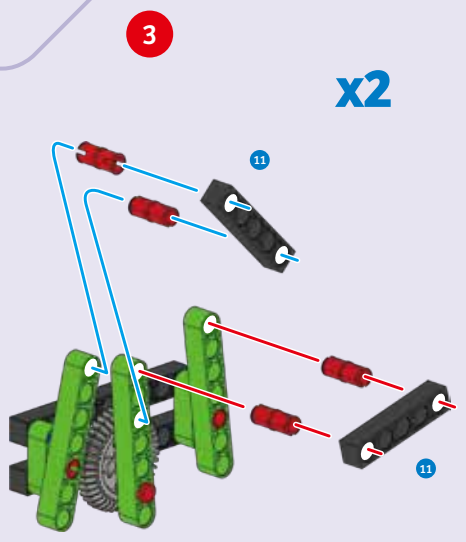
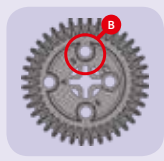
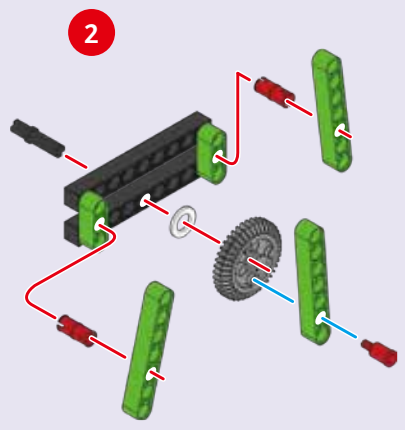
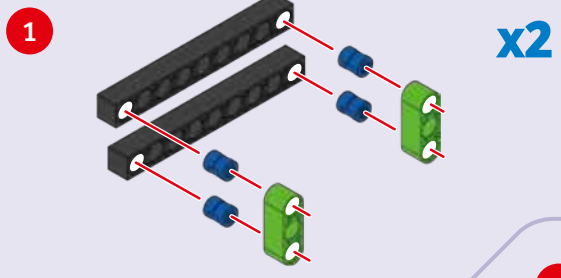

INSECTOID-BOT

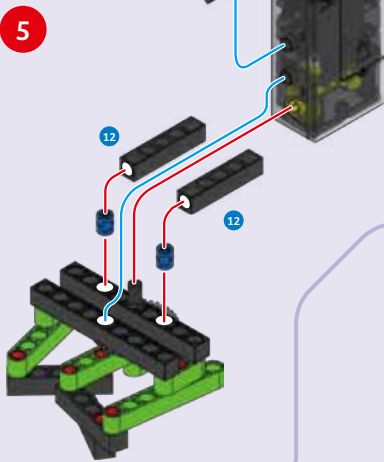

Side view

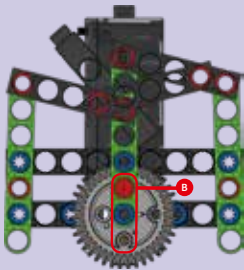
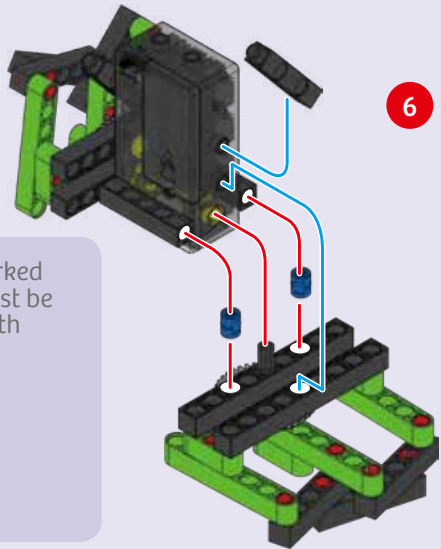
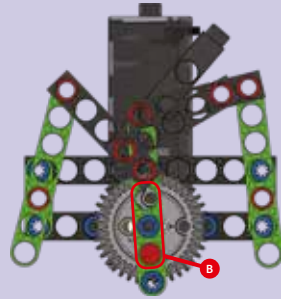

The holes marked with the B must be vertical on both sides.

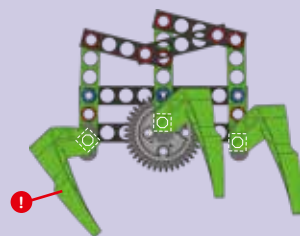
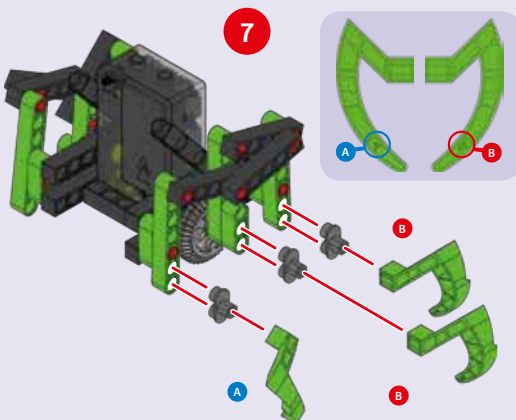

Note! This part is angled differently than the others.



INSECTOID-BOT

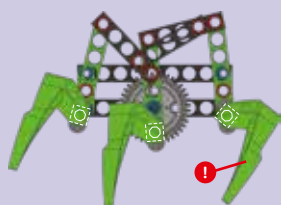

Note! This part is angled differently than the others.

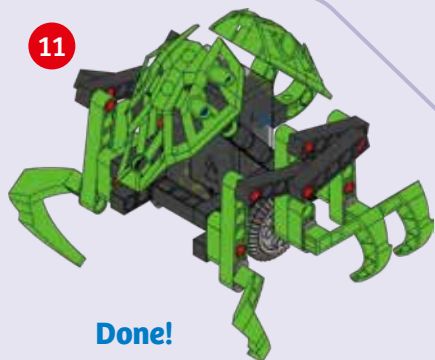
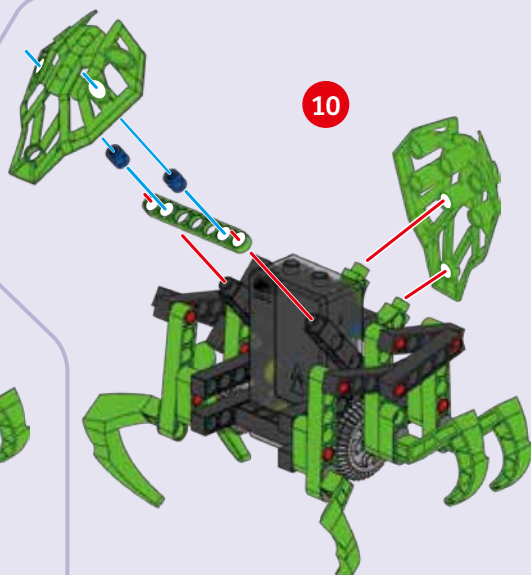
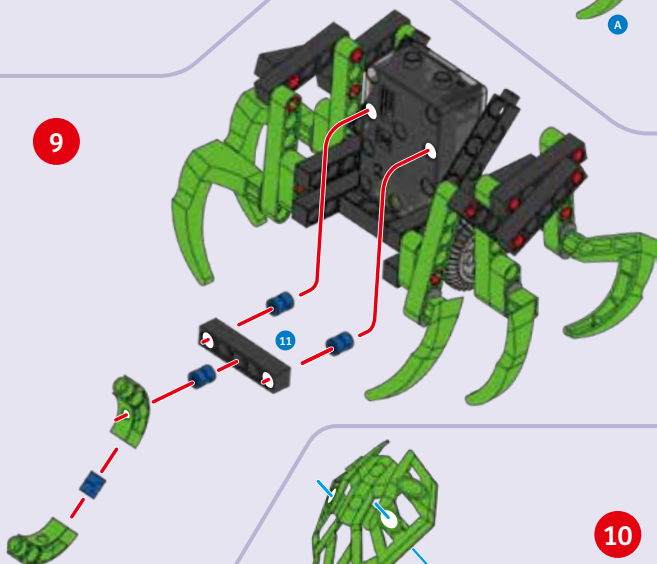
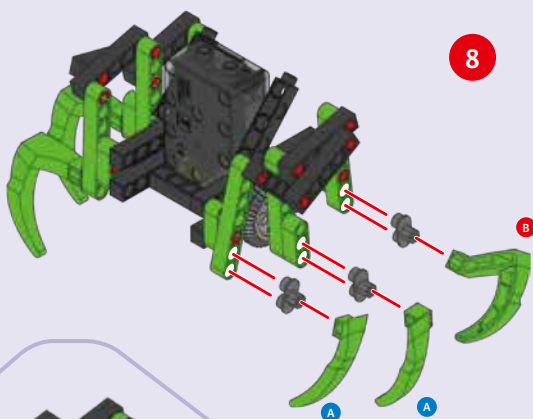

Done!

ROLLING DRAGON-BOT

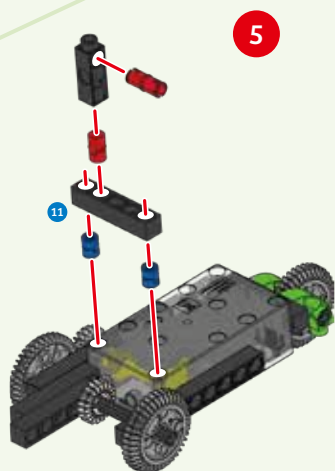
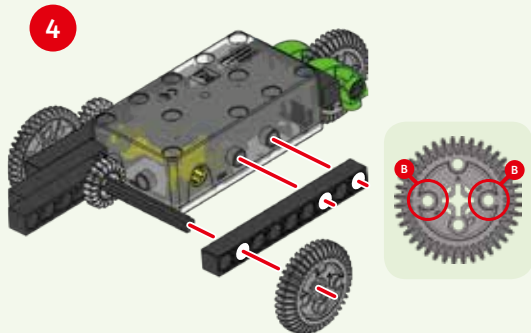
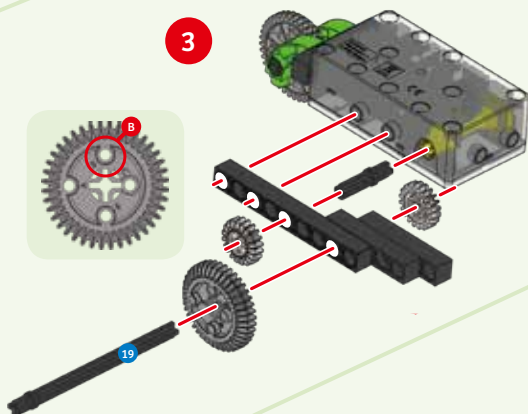
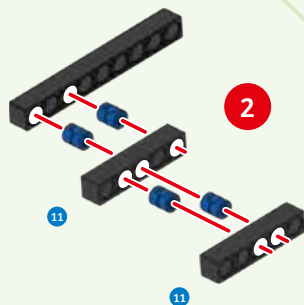
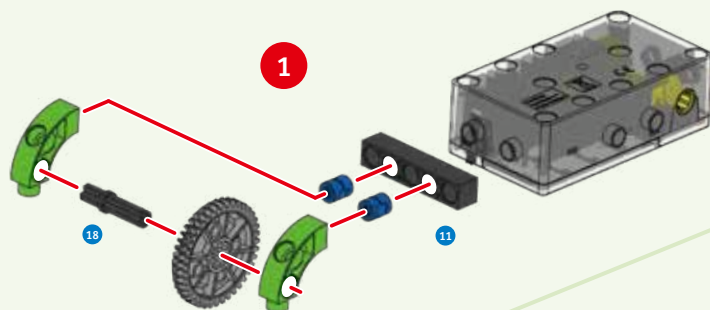



ROLLING DRAGON-BOT

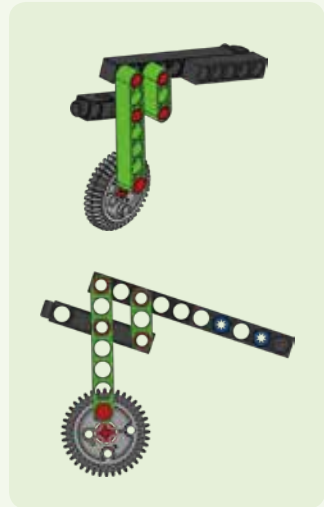
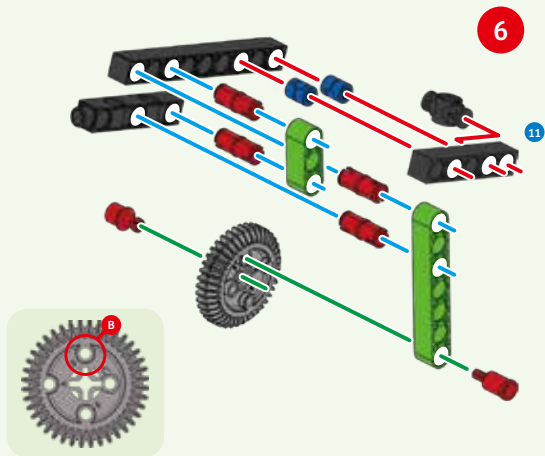

8

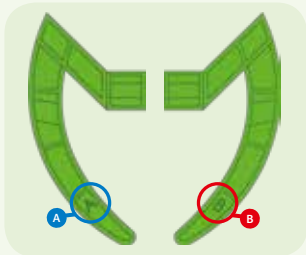

7

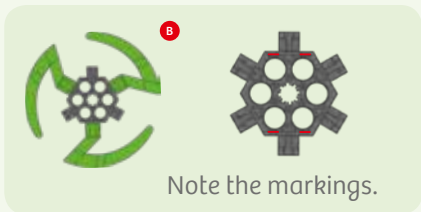
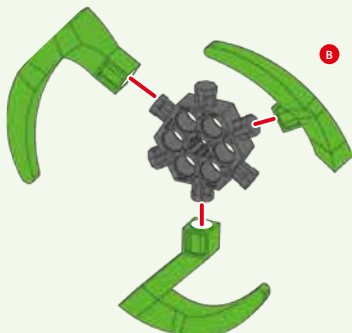
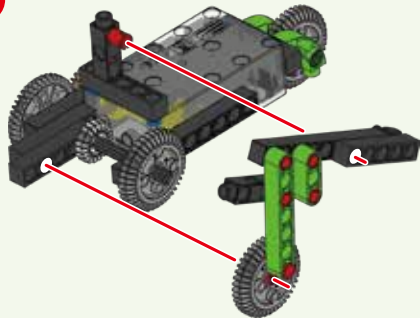

ROLLING DRAGON-BOT

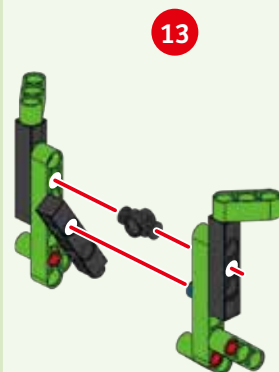
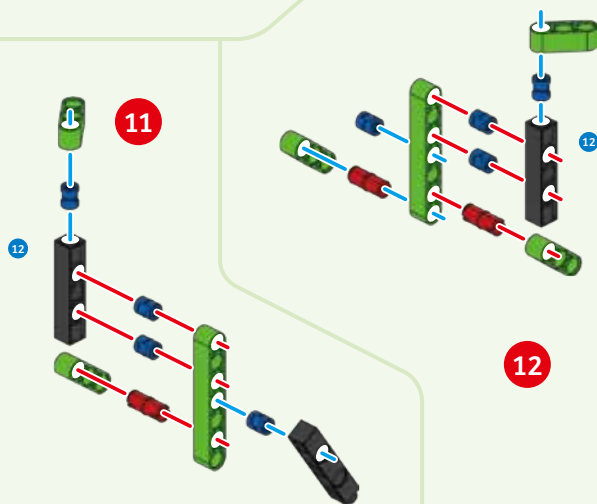
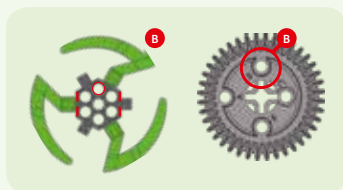
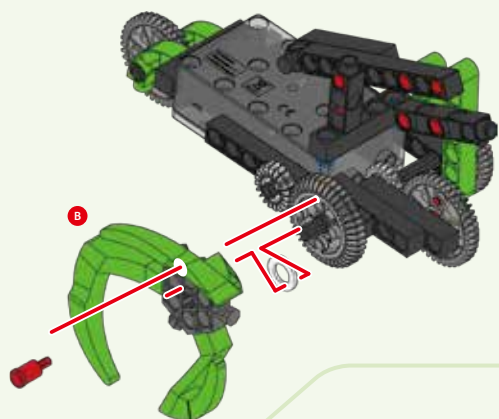
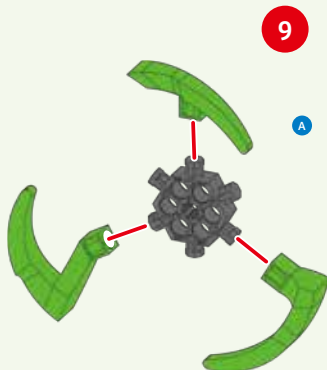



ROLLING DRAGON-BOT

14

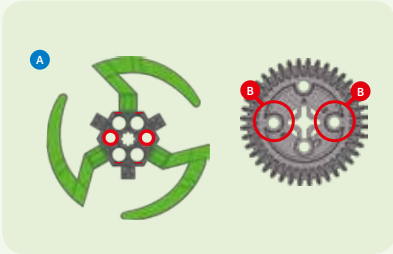
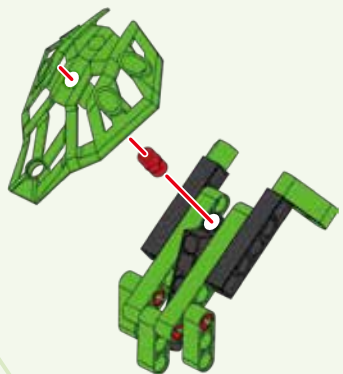

15

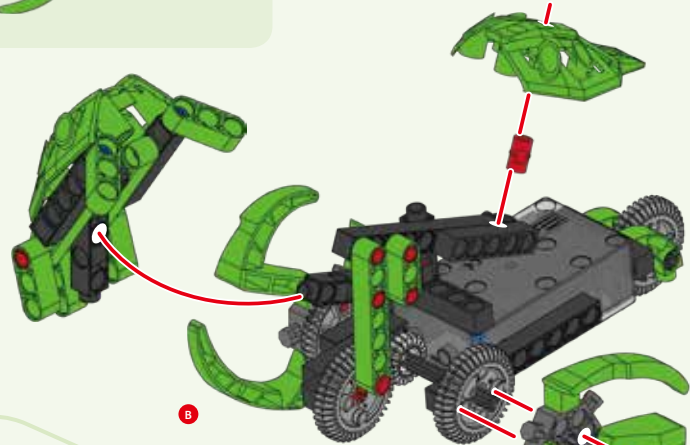

16

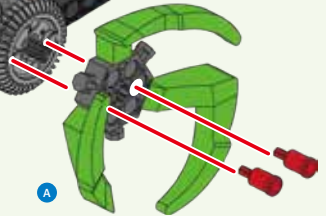
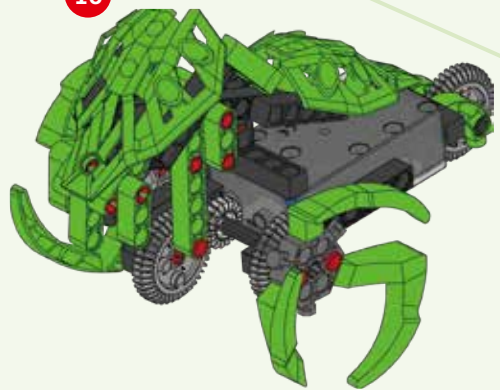

Done!

GRABBER CLAW

1

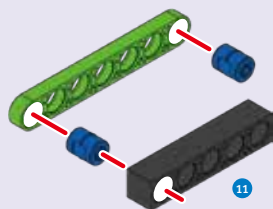

2

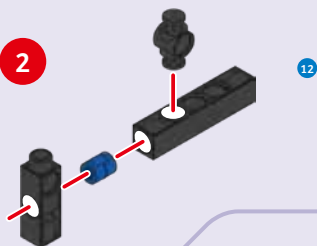

3

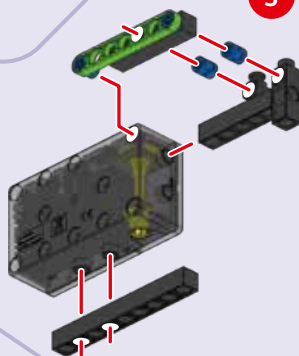

4

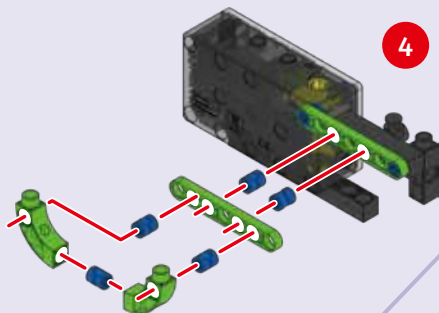

5

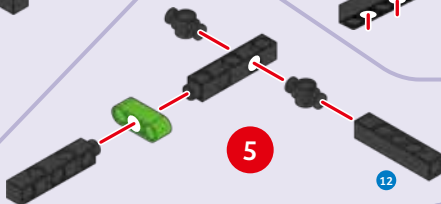

6

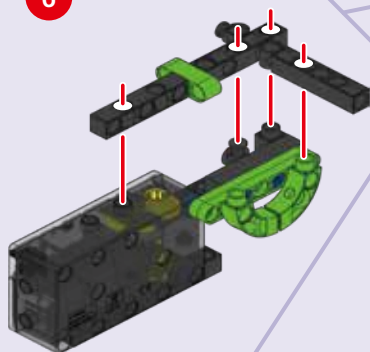

7

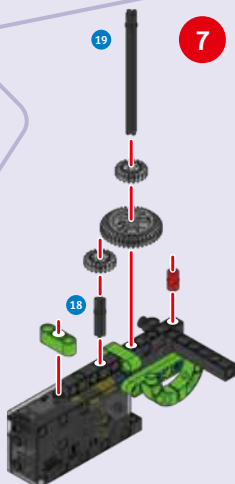

8

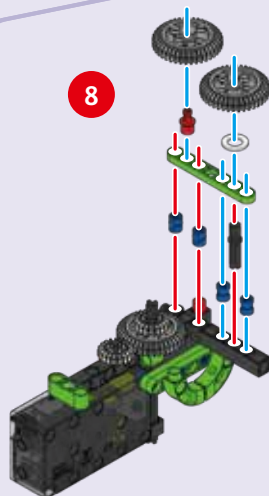



GRABBER CLAW

9

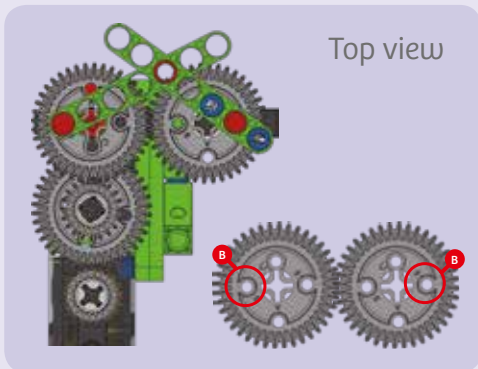
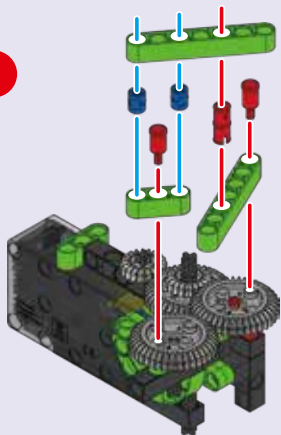

Top view

10

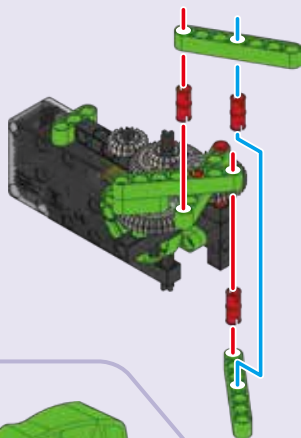

11

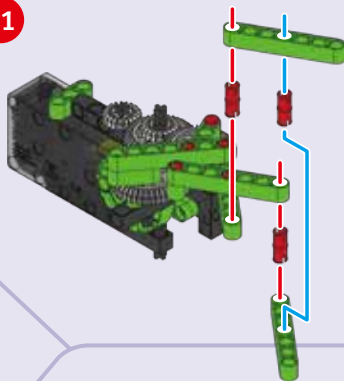

12

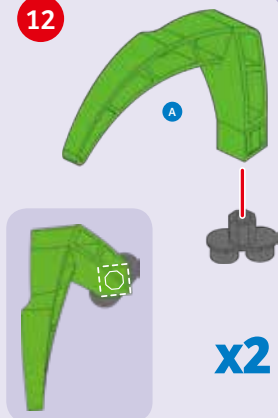

x2

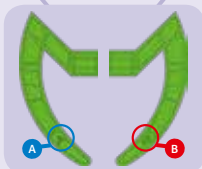

13

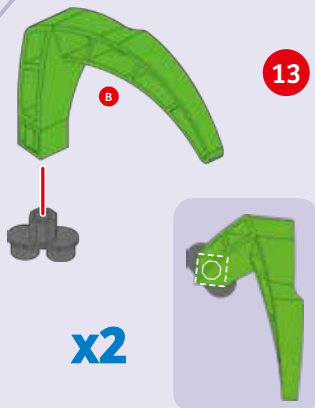

x2

GRABBER CLAW

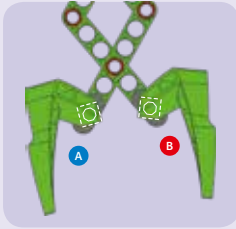

14

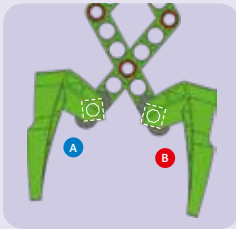
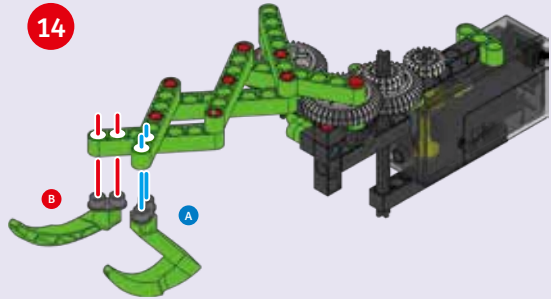

15

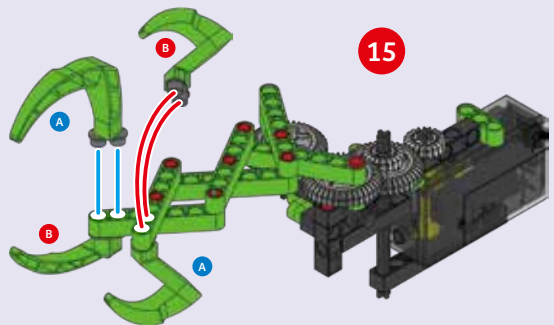

16

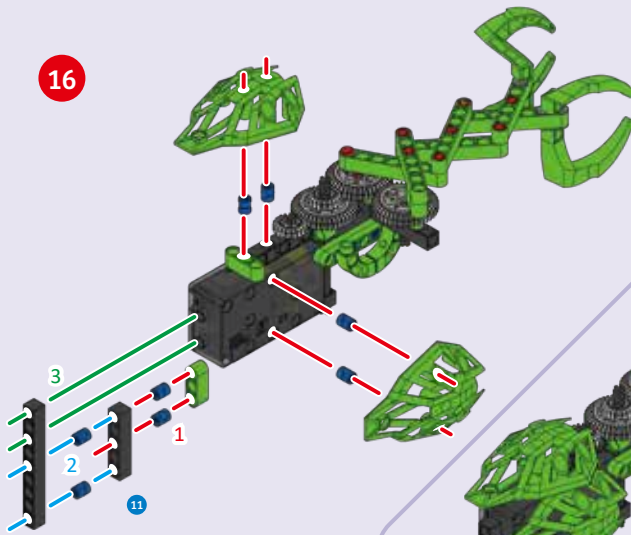

17

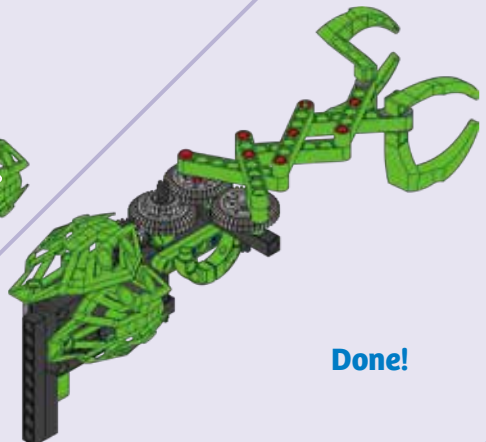

Done!



ALIEN RAPTOR

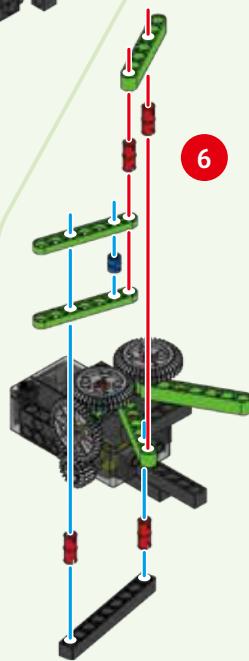
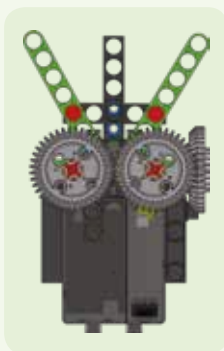
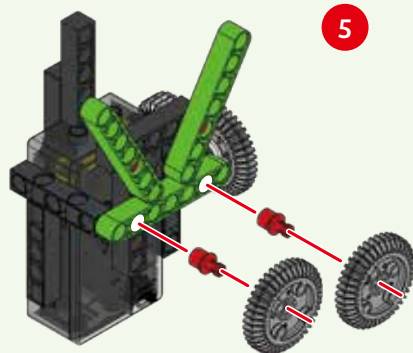
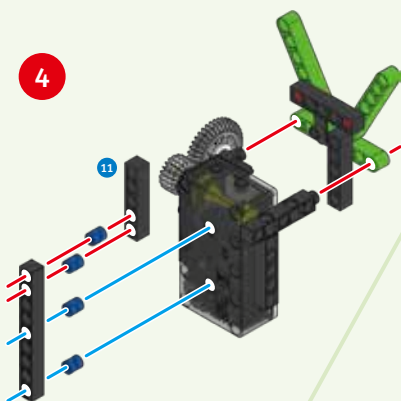
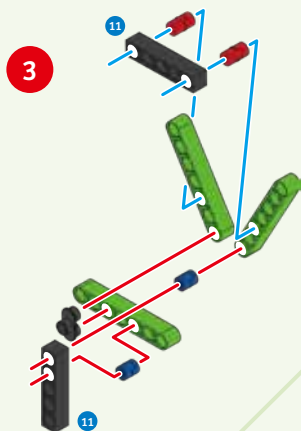
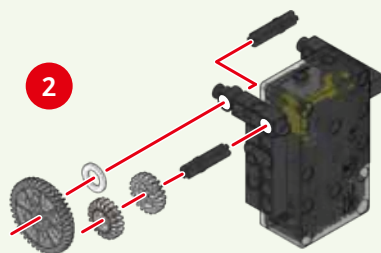
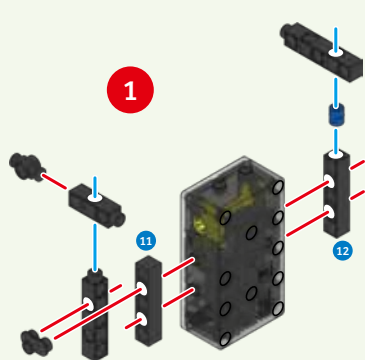

ALIEN RAPTOR

7

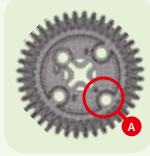
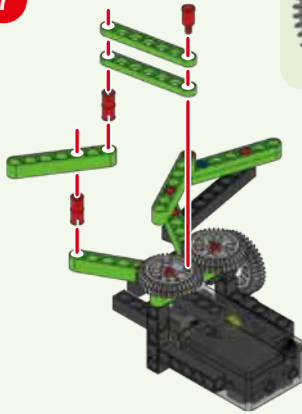

8

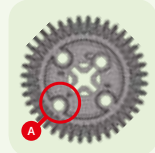
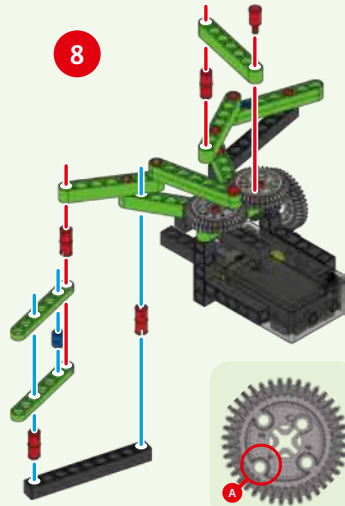

9

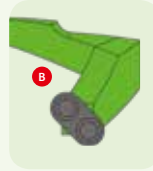
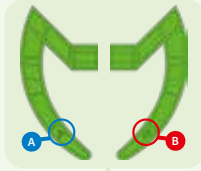
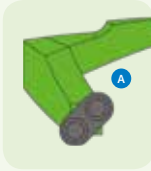
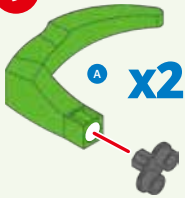

10

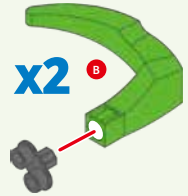

11

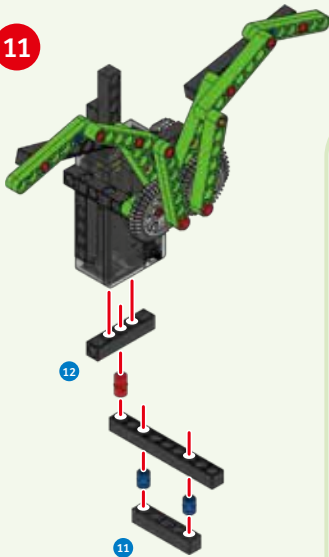

12

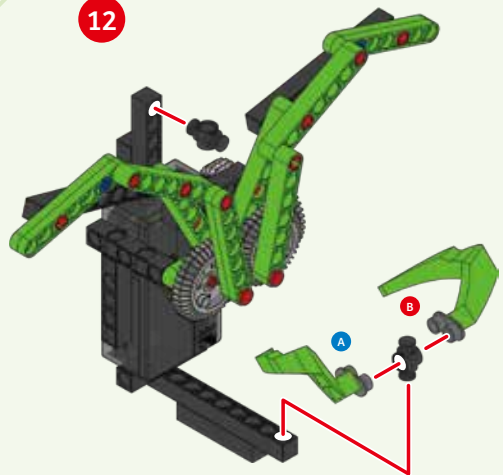



ALIEN RAPTOR

13

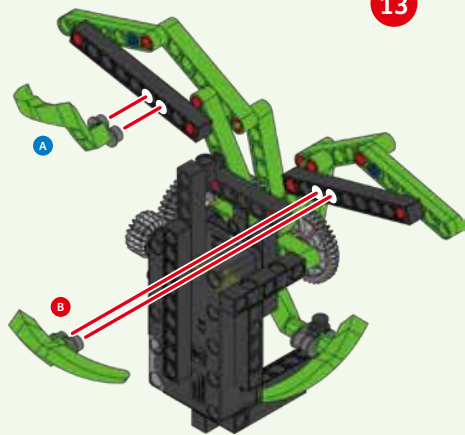

14

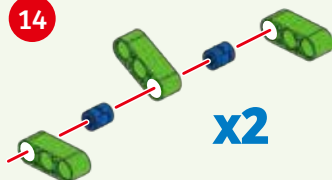

15



16



17

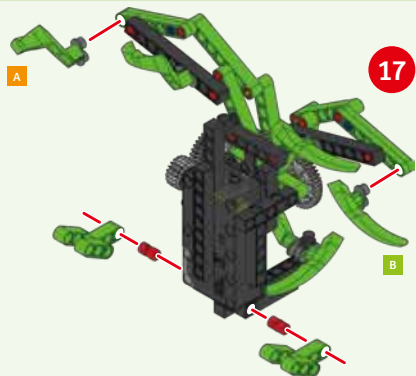

18

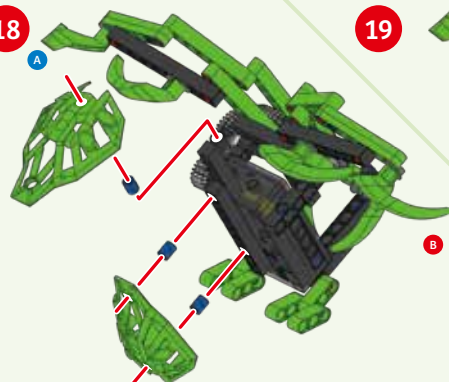

19



ROVING DINO-BOT

1

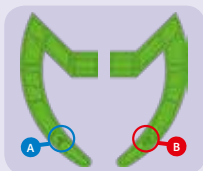
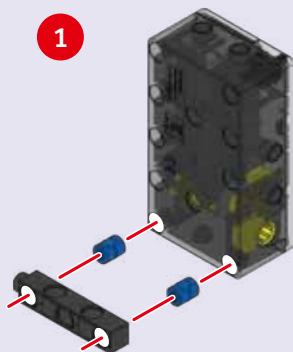

2

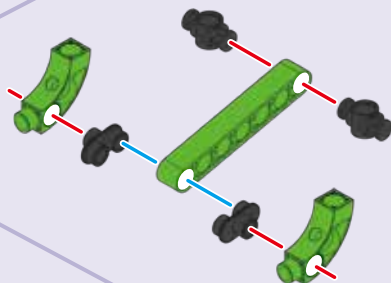

3

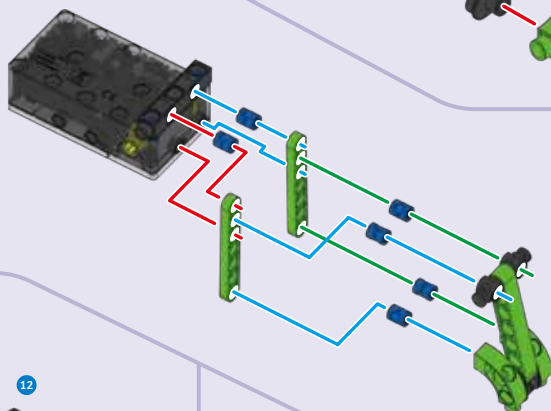

4

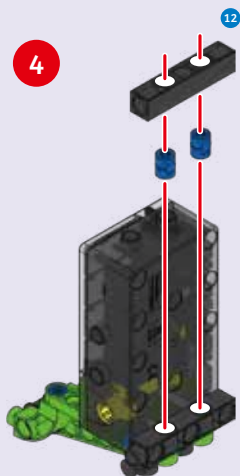

5

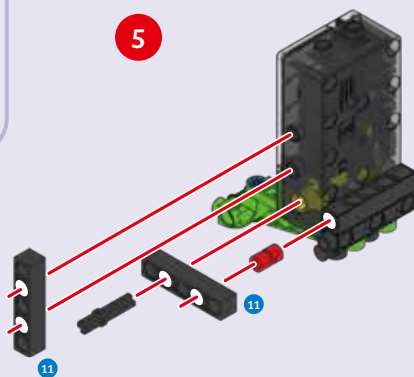



ROVING DINO-BOT

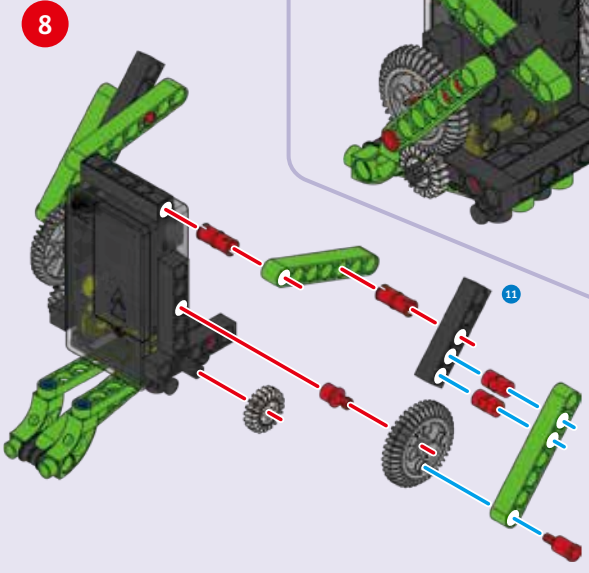
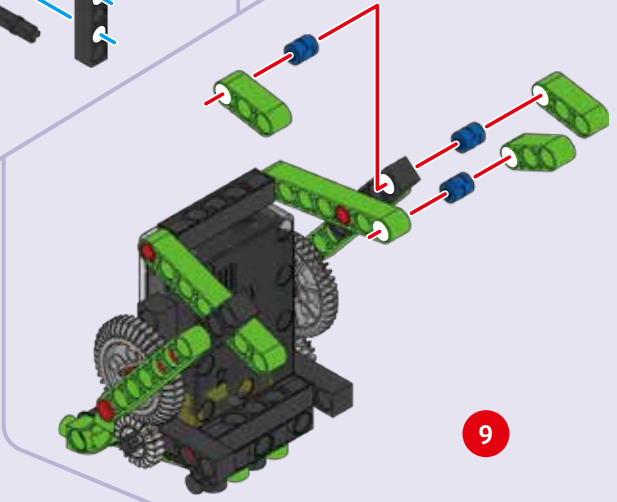
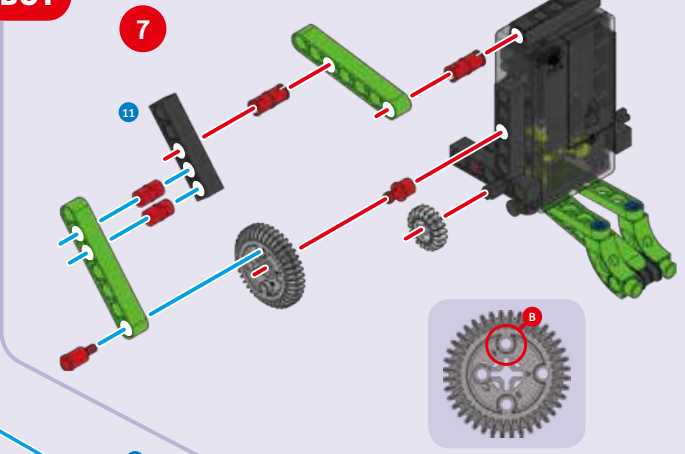
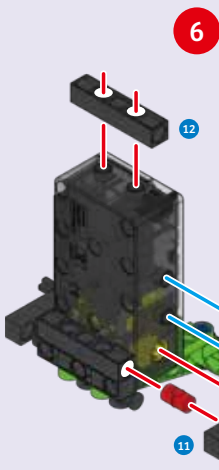

ROVING DINO-BOT

10

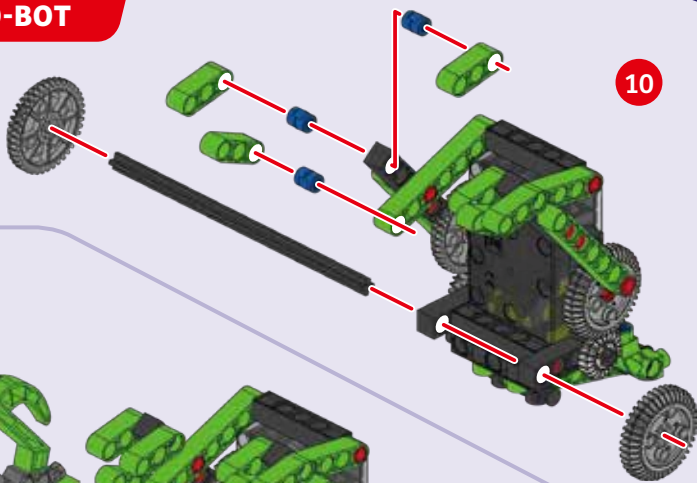

11

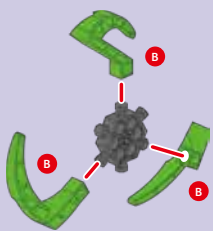
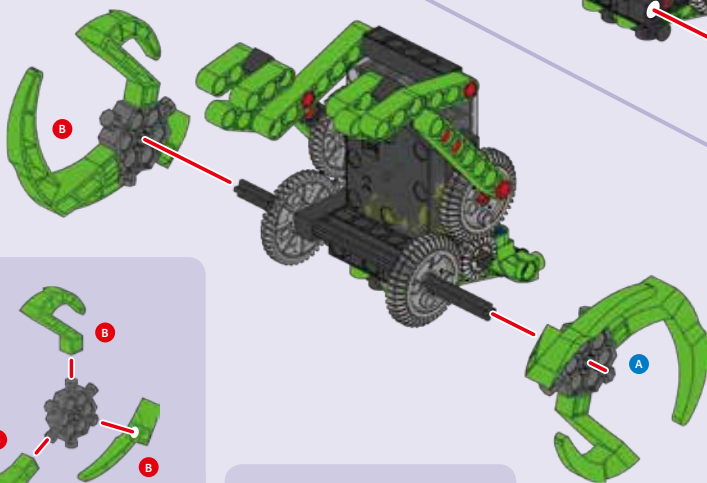

Note the markings.

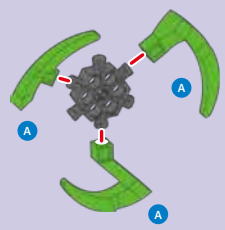

Note the markings.



ROVING DINO-BOT

Front view

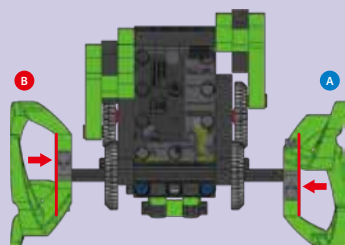

Note! The end of the axle is aligned with the outside of the wheel hub.

12

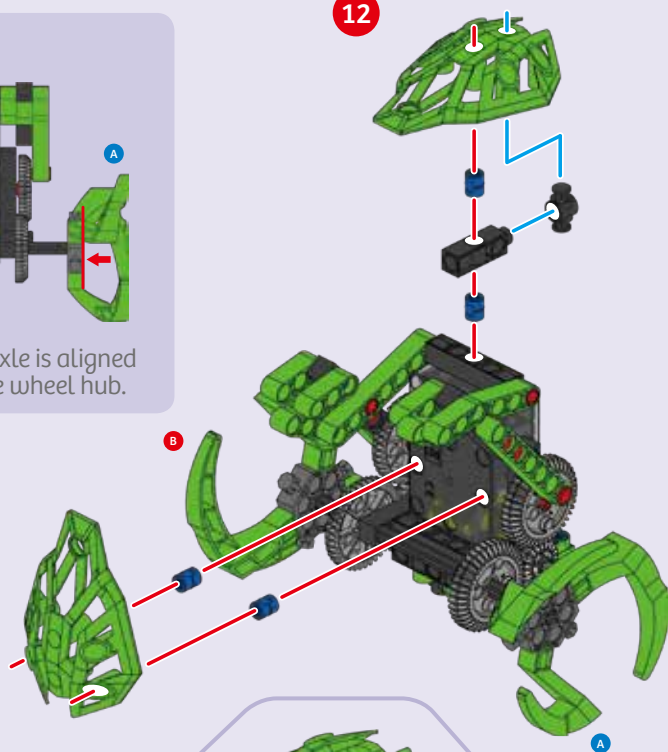

13

Done!

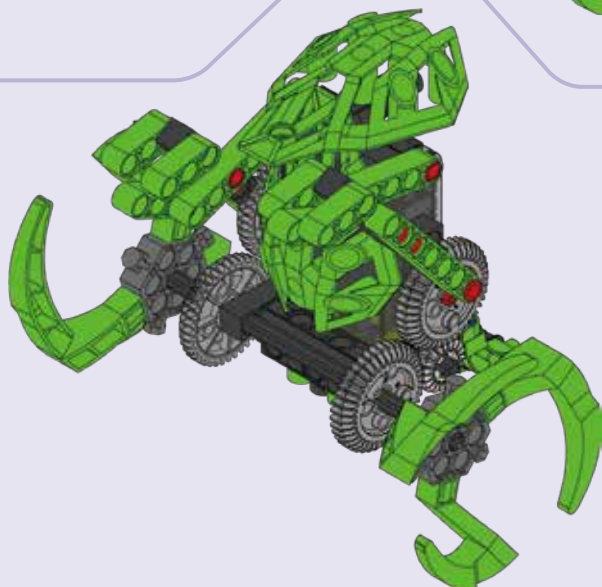

PLAYGROUND SWING

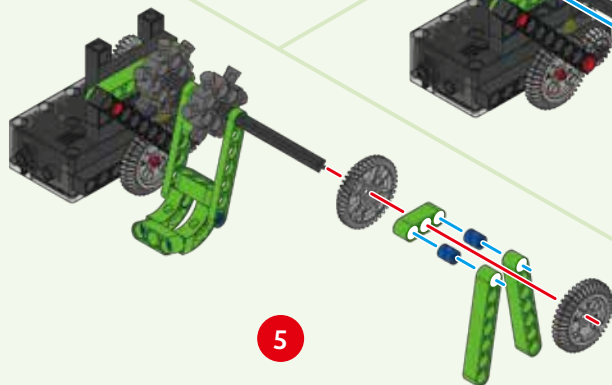
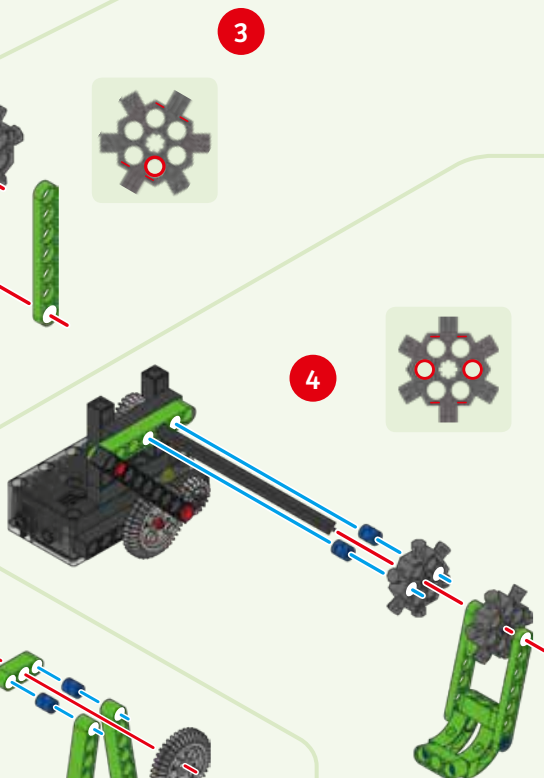
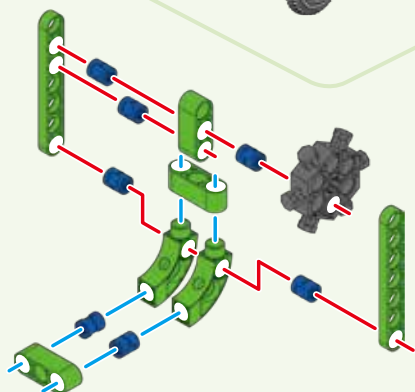
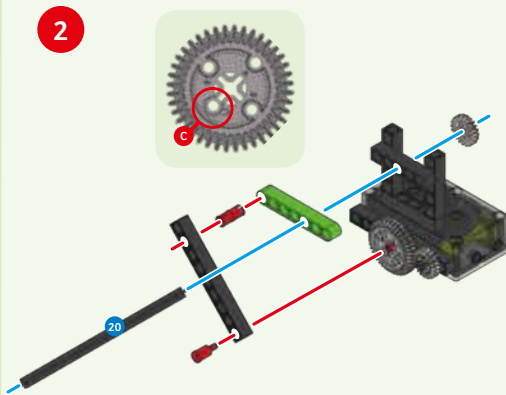
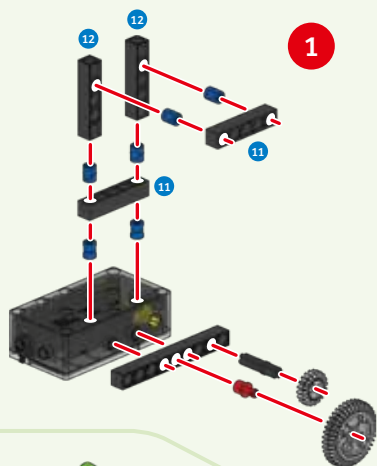



PLAYGROUND SWING

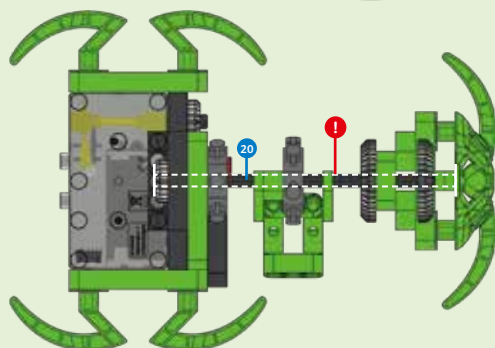
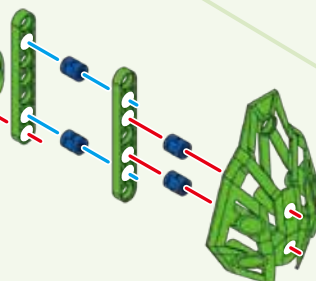
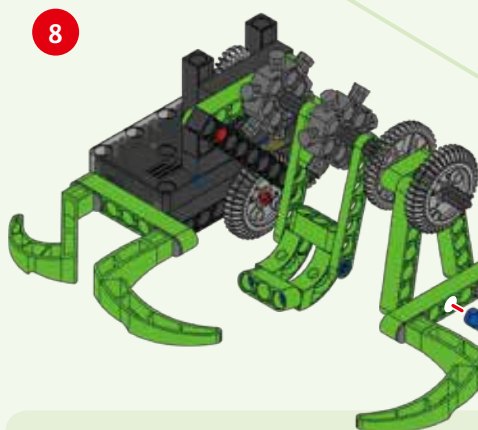
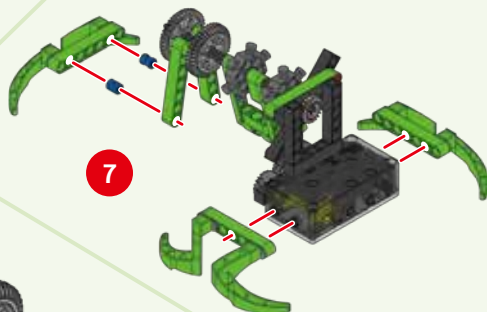
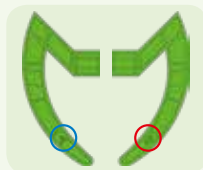
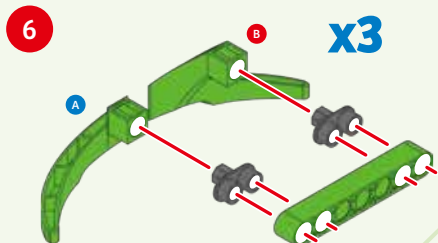

Pay attention to the correct positions of each part. Adjust the parts to the positions in this view.



BIPEDAL ROBOT

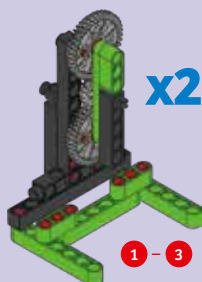

x2

1 - 3

Repeat steps 1 through 3 to build two copies of this foot unit.

1

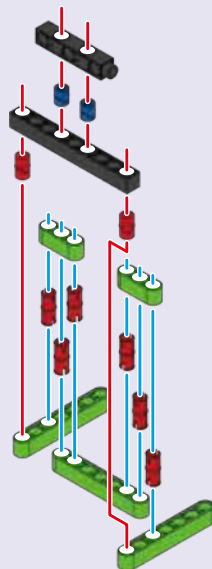

2

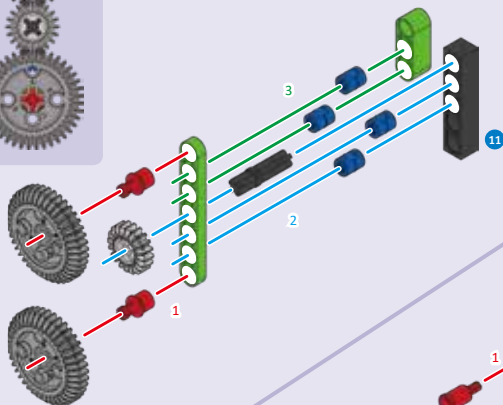

3

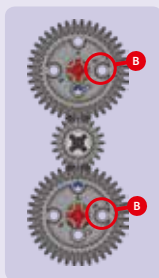
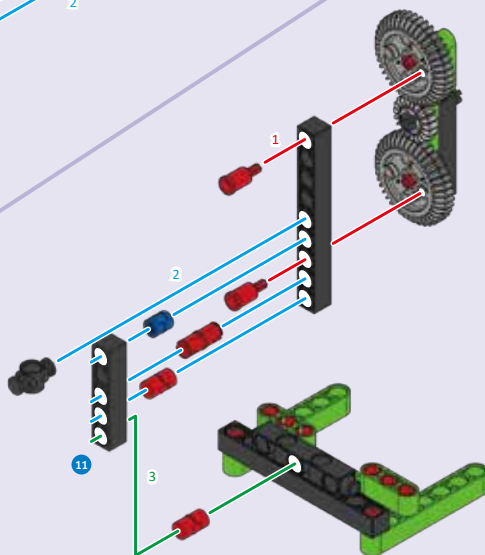



BIPEDAL ROBOT

Side view

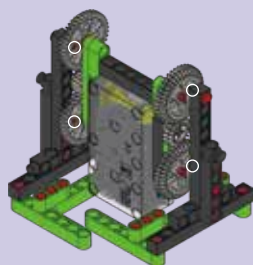

Note the relative position of the holes marked with the B on both sides.

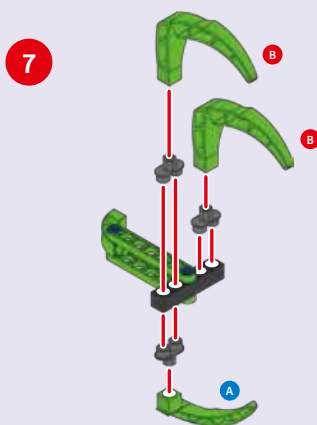
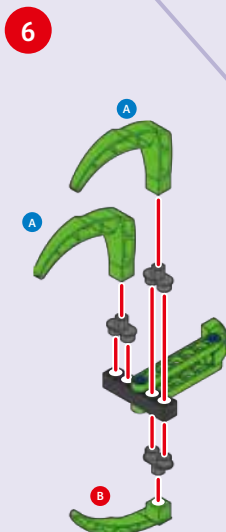
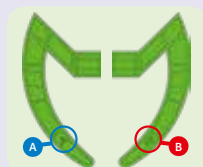
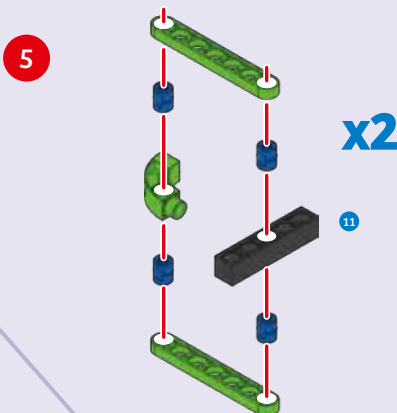
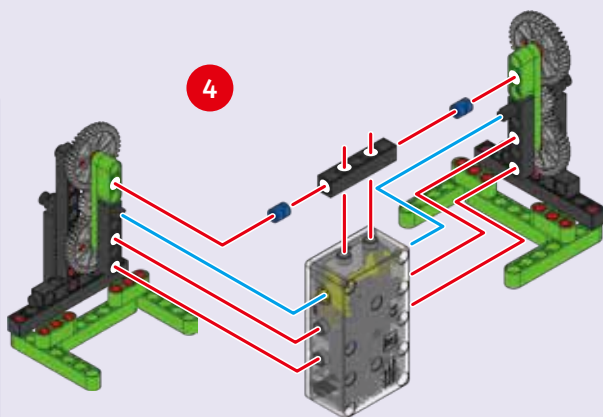

BIPEDAL ROBOT

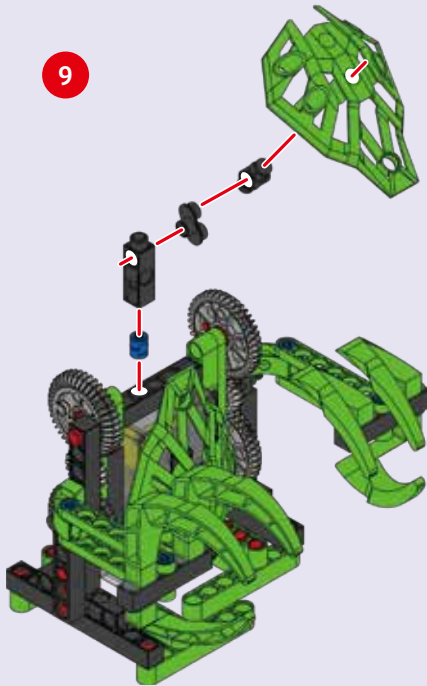
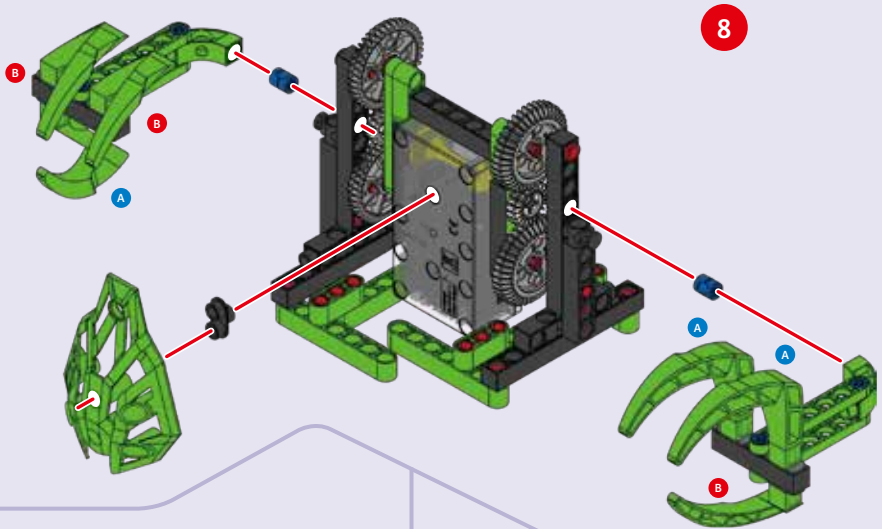

Done!

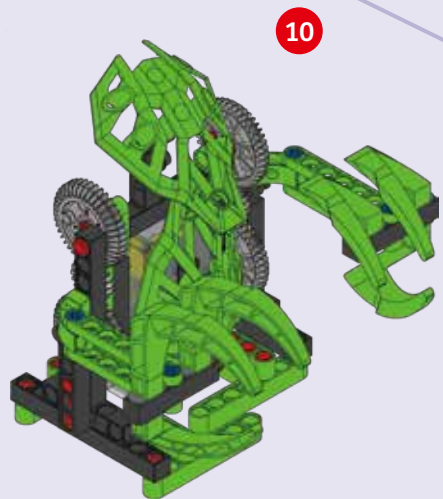



PUMPJACK

1

x2

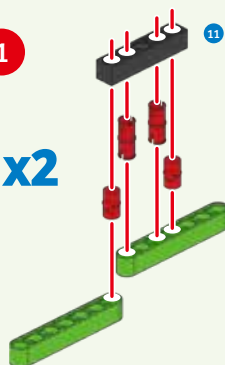

2

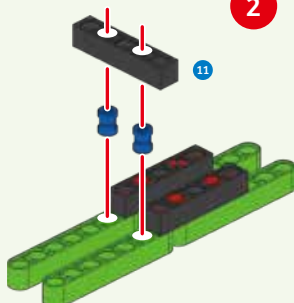

3

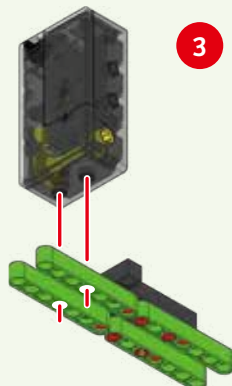

4

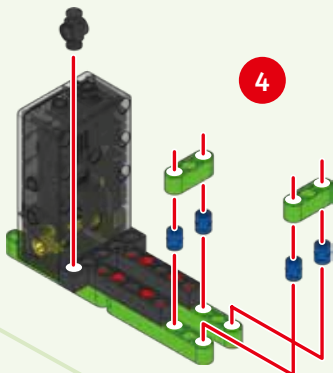

6

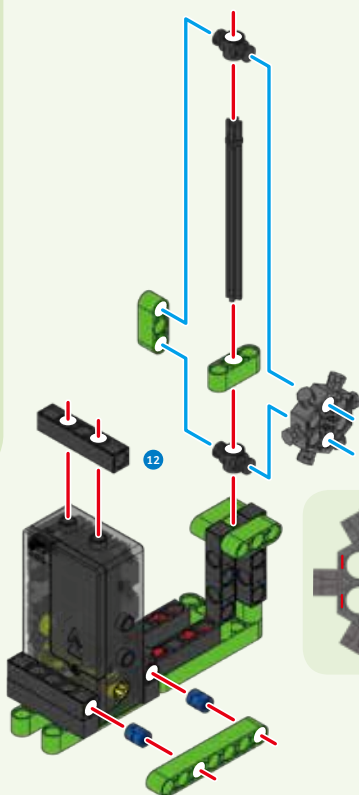

12

11

5

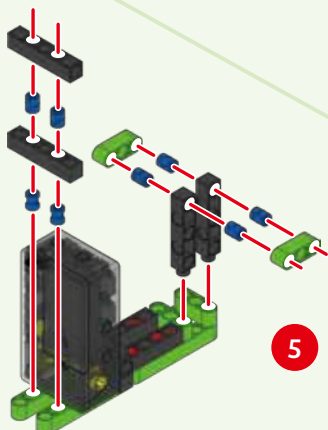

PUMPJACK

7

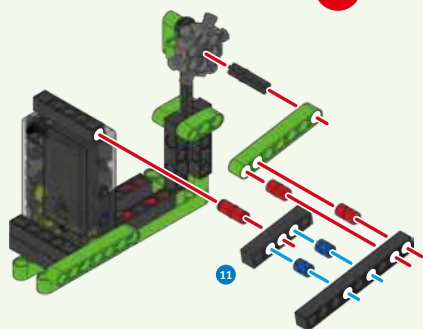

8

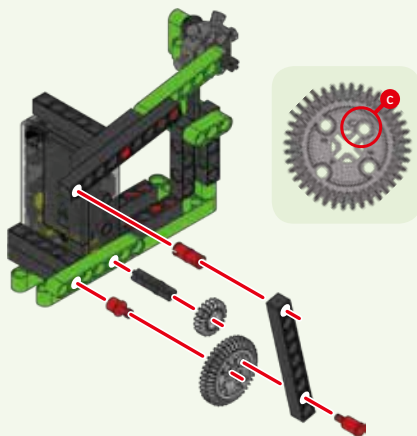

9

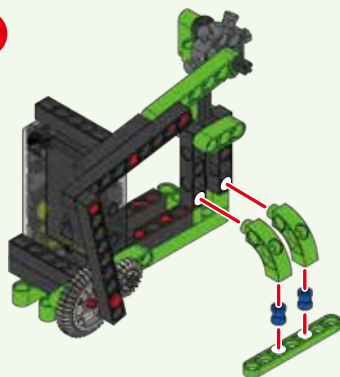

10

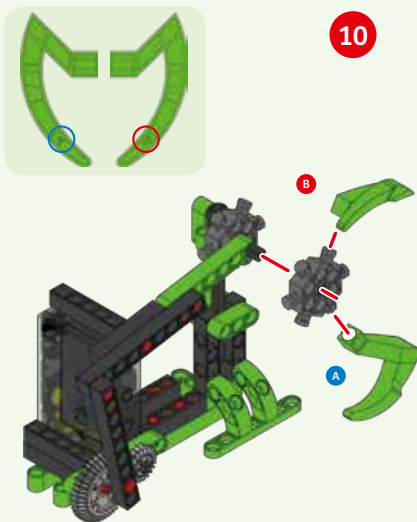

11

Done!





ALIEN FROG-BOT

1

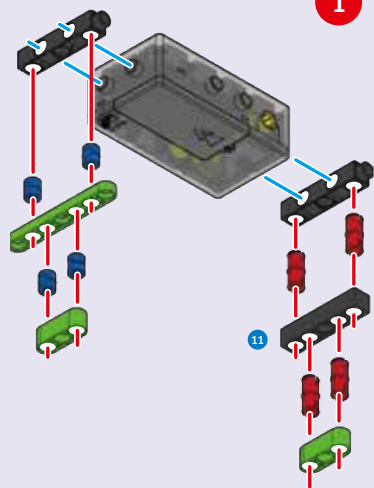

2

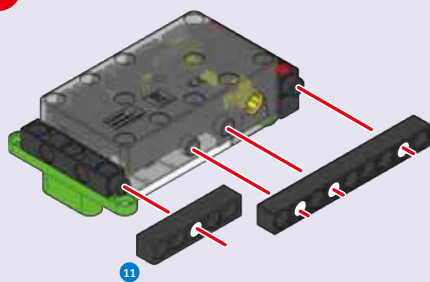

3

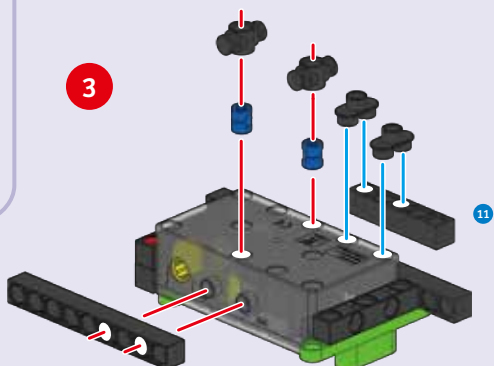

4

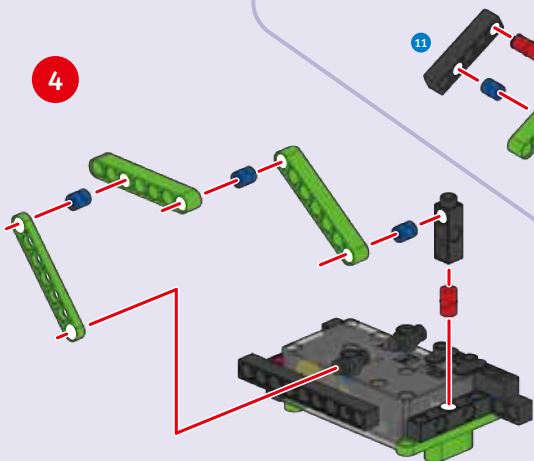

5

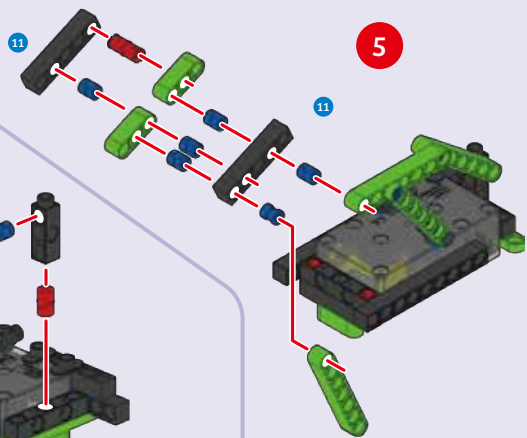

ALIEN FROG-BOT

6

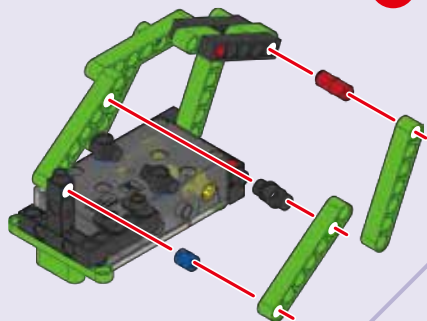

7

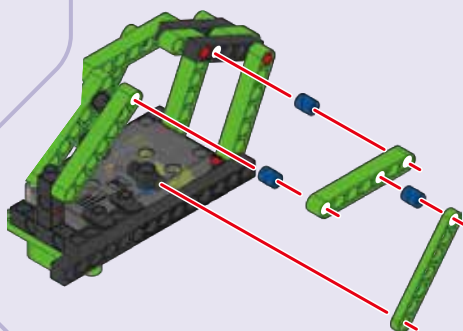

8

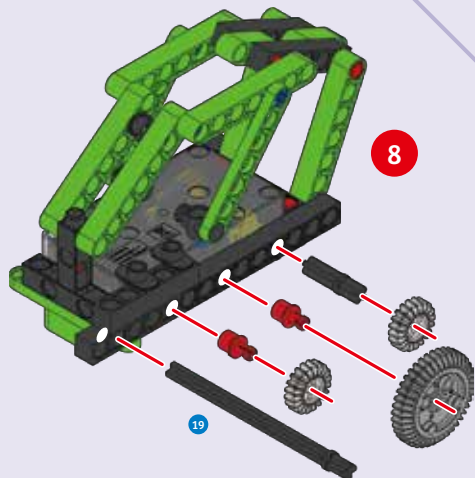

Side view

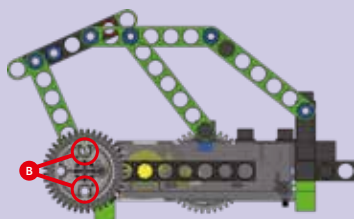

Side view

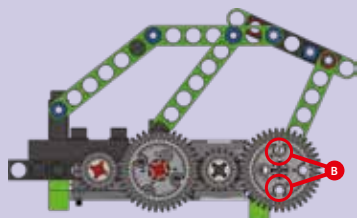

9

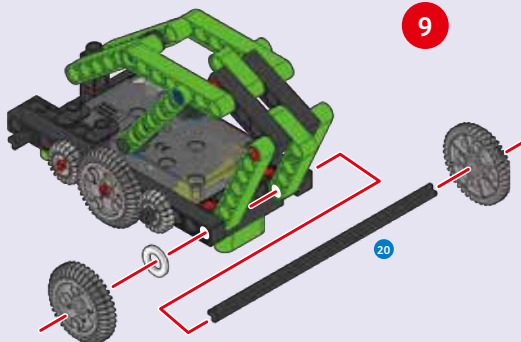



ALIEN FROG-BOT

10

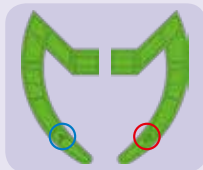
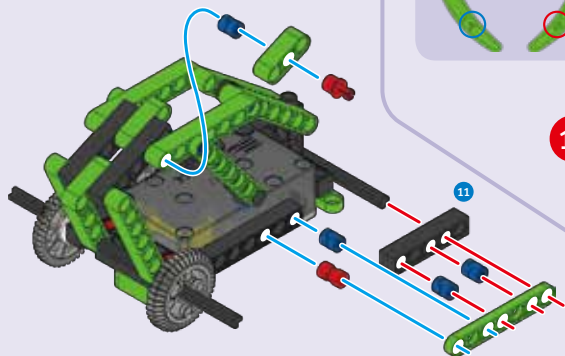

11



Side view



12

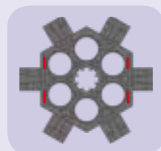
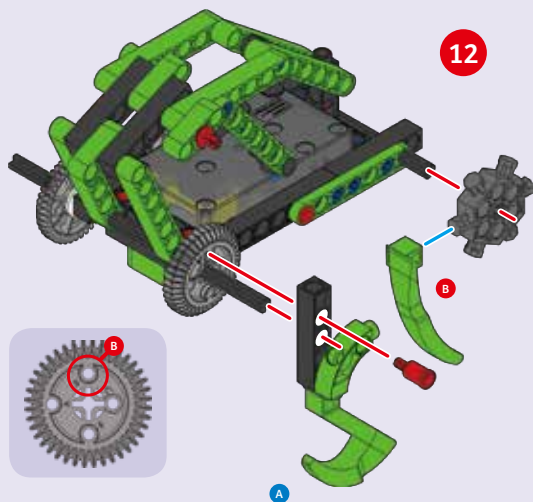

Side view

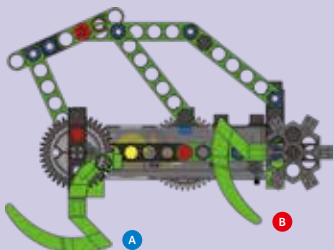

13

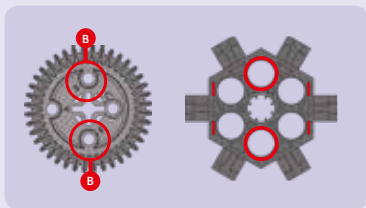
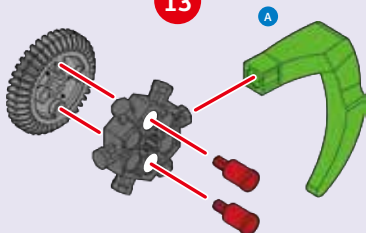

ALIEN FROG-BOT

14

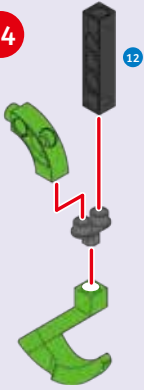

Side view



15

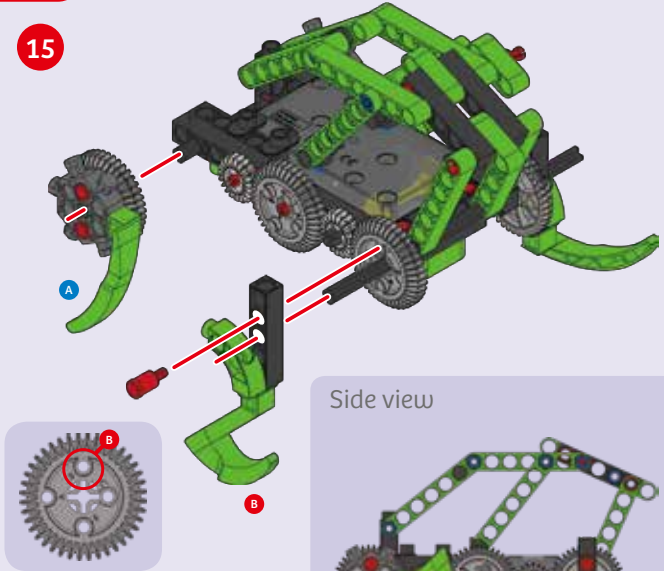

Side view

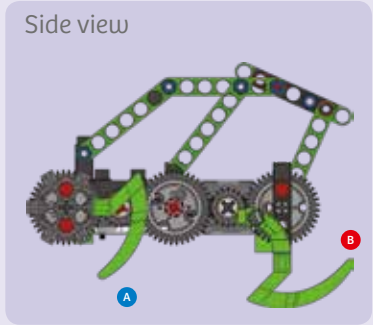

16

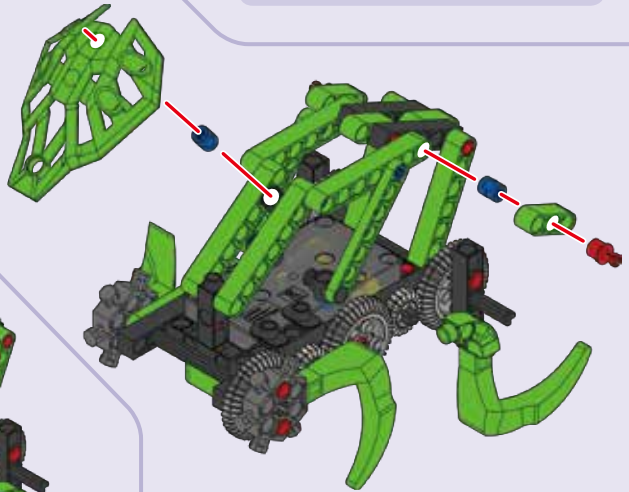

17

Done!



LINKAGES

All of the models in this kit make use of mechanisms called linkages.

A **linkage** is a mechanical assembly of rigid **links** (or rods) connected at movable **joints**. Picture the rigid rods in this kit linked together with the rotating joint pins: that is a linkage! Linkages can be **open**

or **closed** chains, in which each link is connected to at least one other link. In open linkages, the end of a rod is not connected to another rod. In closed linkages, all of the rods' ends are connected to other rods.

Engineers use linkages to change the **direction of a motion** or **change the size of a force**. Applying a force on one part of a linkage produces a predictable resulting force at another part of a linkage. Linkages can be used in very clever ways to achieve exactly the direction and magnitude of force desired.

Linkages are often grouped by the number of rods: **two-bar**, **three-bar**, and **four-bar linkages** are common.

Four very common types of linkages are as follows. Try building these linkages with the pieces in your kit.

- 1. Reverse Motion Linkage:** One rod moves in one direction when the other moves in the opposite direction.
- 2. Parallel Motion Linkage:** The rods move but at least two rods remain parallel to each other at all times.
- 3. Crank and Slider Linkage:** A rod moves along a straight line in a slider.
- 4. Bell Crank Linkage:** Horizontal movement is converted perpendicularly into vertical movement.

Make these linkages with your kit! Can you find all the linkages in the models you built?

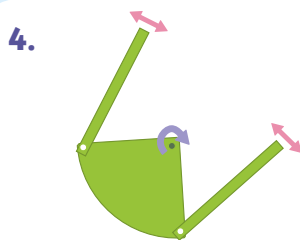
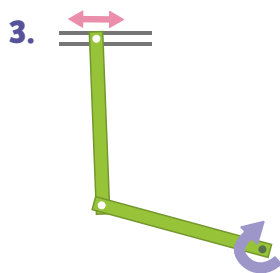
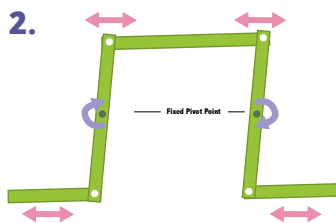
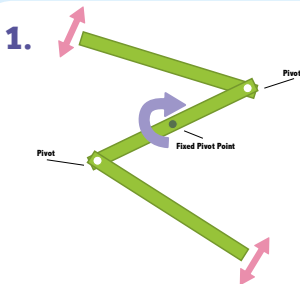

>>> Did you know? A lever is a two-bar linkage!



Kosmos Quality and Safety

More than one hundred years of expertise in publishing science experiment kits stand behind every product that bears the Kosmos name. Kosmos experiment kits are designed by an experienced team of specialists and tested with the utmost care during development and production. With regard to product safety, these experiment kits follow European and US safety standards, as well as our own refined proprietary safety guidelines. By working closely with our manufacturing partners and safety testing labs, we are able to control all stages of production. While the majority of our products are made in Germany, all of our products, regardless of origin, follow the same rigid quality standards.

1st Edition 2018 © 2018 Franckh-Kosmos Verlags-GmbH & Co. KG, Pfizerstrasse 5–7, 70184 Stuttgart, Germany

This work, including all its parts, is copyright protected. Any use outside the specific limits of the copyright law without the consent of the publisher is prohibited and punishable by law. This applies specifically to reproductions, translations, microfilming, and storage and processing in electronic systems and networks. We do not guarantee that all material in this work is free from copyright or other protection.

Technical product development: Genius Toys Taiwan Co., Ltd.; Dr. Petra Müller

Author: Thames & Kosmos, and Rainer Köthe
Manual Layout: Peggy Bertram and Annabell Goldacker, 599media GmbH, Freiberg, Germany

Manual design concept: Atelier Bea Klenk, Berlin

Manual illustrations: Genius Toy Taiwan Co., Ltd., Taichung, Taiwan, R.O.C., and Thames & Kosmos

Manual photos:

© shutterstock: 1, 49

All remaining images: Thames & Kosmos, Franckh-Kosmos Verlags-GmbH & Co. KG, and Genius Toy Taiwan Co., Ltd.

The publisher has made every effort to locate the holders of image rights for all of the photos used. If in any individual cases any holders of image rights have not been acknowledged, they are asked to provide evidence to the publisher of their image rights so that they may be paid an image fee in line with the industry standard.

1st English Edition © 2018 Thames & Kosmos, LLC, Providence, RI, U.S.A.

® Thames & Kosmos is a registered trademark of Thames & Kosmos, LLC.

Author: Thames & Kosmos, and Rainer Köthe
Manual Layout: Mark Geary
Editing: Camille Duhamel, Ted McGuire
Additional Graphics and Packaging: Dan Freitas

Distributed in North America by Thames & Kosmos, LLC.
Providence, RI 02903

Phone: 800-587-2872; Web: www.thamesandkosmos.com

Distributed in United Kingdom by Thames & Kosmos UK LP.
Cranbrook, Kent TN17 3HE

Phone: 01580 713000; Web: www.thamesandkosmos.co.uk

We reserve the right to make technical changes.
Printed in Taiwan / Imprimé en Taiwan

